

**Other Briggs & Stratton
Commercial Power Repair Manuals:**

272147 - Single Cylinder OHV Air-Cooled Engines

272144 - Vanguard™ Twin Cylinder OHV Air-Cooled Engines

275429 - Vanguard™ Twin Cylinder OHV Liquid-Cooled Engines

MS-0750 - Vanguard™ 3-Cylinder OHV Liquid-Cooled Gasoline Engines

MS-1055 - Vanguard™ 3-Cylinder OHV Liquid-Cooled Diesel Engines



COMMERCIAL POWER

Briggs & Stratton



COMMERCIAL POWER
REPAIR MANUAL

**Vanguard™ Twin Cylinder
OHV Liquid-Cooled Engines**



Quality Starts With A
Master Service Technician



Equipment & Engine
Training Council



0 24847 06219 9

BRIGGS & STRATTON CORPORATION
Milwaukee, WI 53201
Part No. 275429-1/04 Printed in U.S.A.
www.briggsandstratton.com

VANGUARD™ TWIN CYLINDER OHV LIQUID-COOLED ENGINES

Part No. 275429-1/04

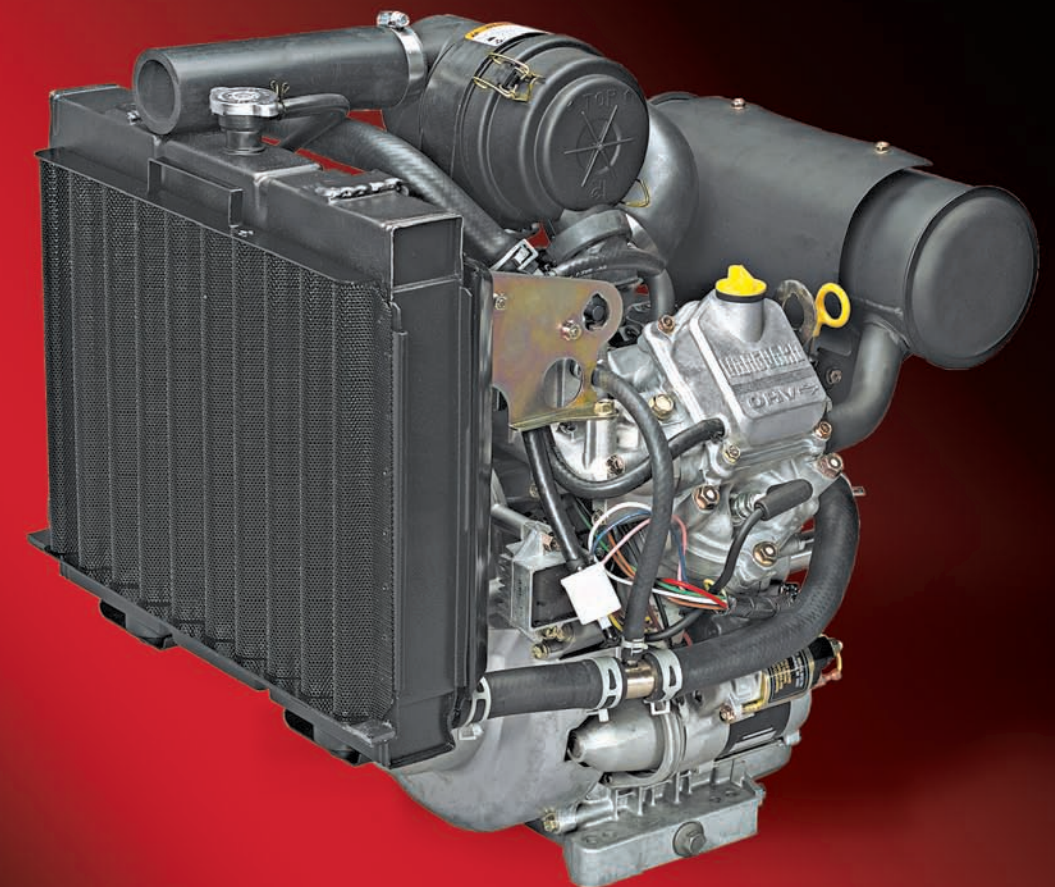



MODEL 473100
2 CYLINDER LIQUID COOLED ENGINE
COMMERCIAL POWER

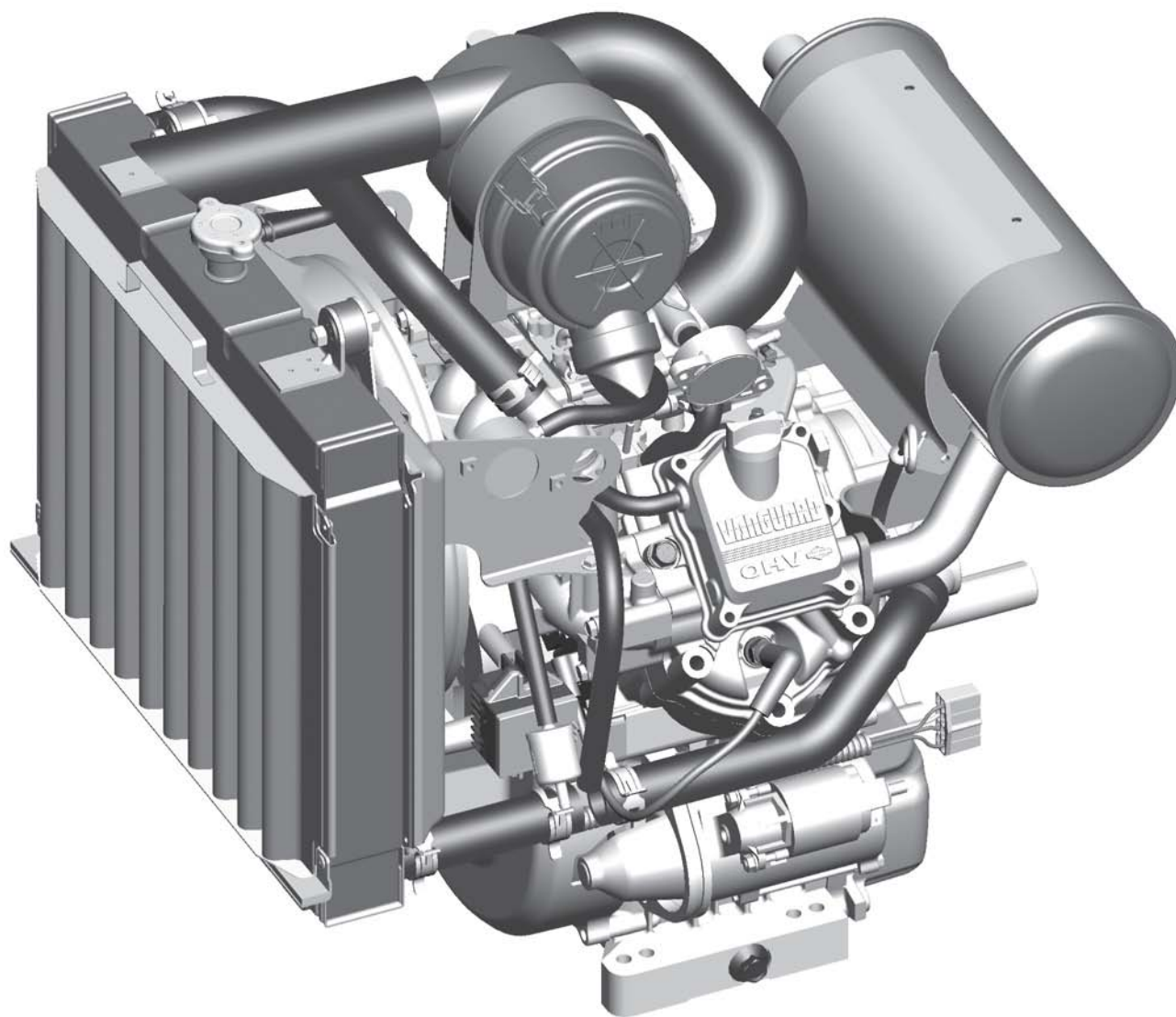



SAFETY INFORMATION

The Briggs & Stratton engine is made of the finest material in a state-of-the-art manufacturing facility. Please understand that Briggs & Stratton sells engines to original equipment manufacturers. It also sells to others in the distribution chain who may sell to the ultimate consumer, an equipment manufacturer, another distributor or a dealer. As a result, Briggs & Stratton does not necessarily know the application on which the engine will be placed. For that reason, carefully read and understand the operating instructions of the equipment before you repair or operate.

You should also understand that there are equipment applications for which Briggs & Stratton does not approve the use of its engines. Briggs & Stratton engines are not to be used on vehicles with less than 4 wheels. This includes motor bikes, aircraft products and all terrain vehicles. Moreover, Briggs & Stratton does not approve of its engines being used in competitive events. FOR THAT REASON, BRIGGS & STRATTON ENGINES ARE NOT AUTHORIZED FOR ANY OF THESE APPLICATIONS. Failure to follow this warning could result in death, serious injury (including paralysis) or property damage.

IN THE INTEREST OF SAFETY

The safety alert symbol () is used to identify safety information about hazards that can result in personal injury.

A signal word (**DANGER**, **WARNING**, or **CAUTION**) is used with the alert symbol to indicate the likelihood and the potential severity of injury. In addition, a hazard symbol may be used to represent the type of hazard.



DANGER indicates a hazard which, if not avoided, **will result in death or serious injury**.



WARNING indicates a hazard which, if not avoided, **could result in death or serious injury**.



CAUTION indicates a hazard which, if not avoided, might result in minor or moderate injury.

CAUTION: When this signal word is used without the alert symbol, it indicates a situation that could result in damage to the engine.

- Prior to work, read and understand the section(s) of this manual that pertain to the job. Follow all safety warnings.
- Wear suitable eye protection.
- Prevent accidental starting by removing spark plug wire from spark plug when servicing engine or equipment. Disconnect negative battery terminal if equipped with electric starting system.
- Periodically clean engine. Keep governor parts free of dirt, grass and other debris which can affect engine speed.
- Always use fresh gasoline. Stale fuel can gum carburetor and cause leakage.
- Check fuel lines and fittings frequently for cracks or leaks and replace if necessary.



HAZARD SYMBOLS AND MEANINGS

Explosion	Fire	Shock
Goggles	Chemical Burns	Explosive Pressure
Kick Back	Hot Surface	Entanglement
Toxic Fumes	Read	Disconnect Spark Plug

SFT-01

WARNING

- The engine exhaust from this product contains chemicals known to the State of California to cause cancer, birth defects or other reproductive harm.

SFT-03

DANGER

Running engines produce heat. Temperatures of muffler and surrounding areas can reach 150°F (65°C). Severe burns can occur on contact.

- Allow muffler, engine cylinder fins and radiator to cool before touching.
- Remove accumulated combustables from muffler area and cylinder area.
- Install and maintain in working order a spark arrestor before using equipment on forest-covered, brush-covered unimproved land. The state of California requires this (Section 4442 of the Public Resources Code). Other states may have similar laws. Federal laws apply on federal land.

SFT-08

WARNING

Gasoline and its vapors are extremely flammable and explosive. Fire or explosion can cause severe burns or death.

When adding fuel:

- Turn engine **OFF** and let engine cool at least 2 minutes before removing.
- Fill fuel tank outdoors or in a well ventilated area.
- Do not overfill fuel tank. Fill tank to approximately 1-1/2 inches below top of neck to allow for fuel expansion.
- Keep gasoline away from sparks, open flames, pilot lights, heat and other ignition sources.
- Check fuel lines, tank, cap and fittings frequently for cracks or leaks and replace if necessary.

When starting engine:

- Make sure spark plug, muffler, fuel cap and air cleaner are in place.
- Do not crank engine with spark plug removed.
- If fuel spills, wait until it evaporates before starting engine.
- If engine floods, set choke to **OPEN/RUN** position. Place throttle in **FAST** and crank until engine starts.

When operating equipment:

- Do not tip engine or equipment at an angle which would cause fuel to spill.
- Do not choke carburetor to stop engine.

When transporting equipment:

- Transport with fuel tank empty or with fuel shut-off valve set to **OFF**.

When storing gasoline or equipment with fuel in tank:

- Store away from furnaces, stoves, water heaters or other appliances that have a pilot light or other ignition source because they can ignite gasoline vapors.

SFT-05

WARNING

Unintentional sparking can result in fire or electric shock. Unintentional start-up can result in entanglement, traumatic amputation or severe lacerations.

Before performing adjustments or repairs;

- Disconnect spark plug wire and keep it away from spark plug.
- Disconnect negative (-) battery terminal.

When testing for spark;

- Use approved spark plug tester.
- Do not check for spark with the spark plug removed.

SFT-05

DANGER

Engines give off carbon monoxide, an odorless, colorless, poison gas. Breathing carbon monoxide can cause nausea, fainting or death.

- Start and run engine outdoors.
- Do not start or run engine in enclosed area, even if doors or windows are open.

SFT-07

DANGER



Starting engine creates sparking. Sparking can ignite nearby flammable gases. Explosion and fire could result.

- If there is natural or LP gas leakage in the area, do not start engine.
- Do not use pressurized starting fluids because vapors are flammable.

SFT-06

 DANGER	
	<p>Rotating parts can contact or entangle hands, feet, hair, clothing or accessories. Traumatic amputation or severe lacerations can result.</p>
<ul style="list-style-type: none"> ● Operate equipment with guards in place. ● Keep hands and feet away from rotating parts. ● Tie up long hair and remove jewelry. ● Do not wear loose-fitting clothing, dangling drawstrings or items that could become entangled in the equipment. 	
<small>SFT-09</small>	

 DANGER	
	<p>Broken bones, fractures, bruises or sprains could result.</p>
<ul style="list-style-type: none"> ● Remove all external equipment/engine loads before starting engine. ● Direct coupled equipment components such as, but not limited to blades, impellers, pulleys, sprockets, etc., must be securely attached. 	
<small>SFT-10</small>	

 DANGER	
	<p>The cooling system is pressurized.</p>
<ul style="list-style-type: none"> ● Do not remove the radiator cap while the engine is hot. To avoid scalding hot coolant or steam from blowing out of the radiator, use extreme care when removing the radiator cap. If possible, wait for engine to cool. Wrap a thick rag around radiator cap while removing. To release pressure, slowly turn cap counter-clockwise to the first stop. When all pressure has been released, press down on cap and continue turning. 	
<small>SFT-11</small>	



MODEL 473100	
2 CYLINDER LIQUID COOLED ENGINE	
COMMERCIAL POWER	1
SAFETY INFORMATION	2
IN THE INTEREST OF SAFETY	2
SECTION 1	
GENERAL INFORMATION	3
ENGINE IDENTIFICATION	4
MAINTENANCE SCHEDULE	5
FUEL AND OIL RECOMENDATIONS	6
CHANGING OIL AND OIL FILTER.....	7
CHANGE COOLANT	7
CLEANING DEBRIS	8
ADJUST FAN BELT	8
AIR CLEANER MAINTENANCE	8
REPLACE SPARK PLUG	9
SECTION 2	
TROUBLESHOOTING	11
GENERAL INFORMATION	11
WILL NOT START	11
STARTER CURRENT DRAW TEST	12
NO LOAD	
STARTER CURRENT DRAW TEST	13
CHECK CARBURETION	16
FUEL SHUT-OFF SOLENOID	16
FUEL PUMP - GENERAL INFORMATION	17
CYLINDER BALANCE TEST	18
CYLINDER LEAKDOWN TEST	19
CHECKING COOLING SYSTEM	21
CHECK OIL PRESSURE SWITCH	22
CHECK OIL PRESSURE	23
CHARGING SYSTEM	23
BATTERY INFORMATION	25
EQUIPMENT	
AFFECTING ENGINE OPERATION	26
SECTION 3	
ENGINE DISASSEMBLY	27
GENERAL INFORMATION	27
REMOVE MUFFLER	27
REMOVE RADIATOR	27
DISCONNECT FUEL LINES	28
REMOVE FAN ASSEMBLY	28
REMOVE CARBURETOR	29
REMOVE STARTER	30
REMOVE INTAKE MANIFOLD	31
REMOVE ALTERNATOR	32
REMOVE CYLINDER HEADS	32
REMOVE CRANKCASE COVER	33
REMOVE CAMSHAFT	34
REMOVE PISTONS, RODS, CRANKSHAFT .	34
SECTION 4	
ENGINE OVERHAUL	35
CHECK CYLINDER	35
BEARINGS	37
CRANKSHAFT	38
PISTON, RINGS AND CONNECTING ROD	
DISASSEMBLY AND INSPECTION	38
CYLINDER HEAD	
INSPECTION AND REPAIR	41
OIL PUMP	44
REPLACING WATER PUMP SEAL	45
REPLACING STARTER SOLENOID	46



REPLACING PINION GEAR ASSEMBLY 47

CARBURETOR INSPECTION AND REPAIR . 51

SECTION 5

ENGINE ASSEMBLY 57

INSTALL CRANKSHAFT 57

ASSEMBLE

PISTON AND CONNECTING ROD 57

ASSEMBLE PISTON RINGS TO PISTON 57

INSTALL

PISTON AND CONNECTING ROD 58

INSTALL CAMSHAFT 59

INSTALL GOVERNOR GEAR 59

INSTALL CRANKCASE COVER 59

INSTALL STARTER 60

INSTALL ALTERNATOR 60

INSTALL FLYWHEEL 61

INSTALL CYLINDER HEADS 61

INSTALL ROCKER ARMS 61

ADJUST VALVE CLEARANCE 62

INSTALL ARMATURES 62

INSTALL FAN ASSEMBLY 63

INSTALL INTAKE MANIFOLD 64

INSTALL CARBURETOR AND INTAKE ELBOW ASSEMBLY 64

ADJUST GOVERNOR 66

INSTALL MUFFLER 66

INSTALL RADIATOR 67

INSTALL AIR CLEANER ASSEMBLY 67

SECTION 6

FINAL ADJUSTMENTS AND SPECIFICATIONS 71

GENERAL INFORMATION 71

REMOTE GOVERNOR CONTROLS 71

CARBURETOR ADJUSTMENT 72

MODEL 473100 SPECIFICATIONS 75

ENGINE HARNESS 77



SECTION 1 GENERAL INFORMATION

BRIGGS & STRATTON NUMERICAL IDENTIFICATION SYSTEM

This chart explains the unique Briggs & Stratton numerical model designation system. It is possible to determine most of the important mechanical features of the engine by merely knowing the model number. Here is how it works:

- **A.** The first one or two digits indicate the approximate CUBIC INCH DISPLACEMENT.
- **B.** The first digit after the displacement indicates the BASIC DESIGN SERIES, relating to cylinder construction, ignition, general configuration, etc.
- **C.** The second digit after the displacement indicates ORIENTATION OF CRANKSHAFT.
- **D.** The third digit after the displacement indicates TYPE OF BEARINGS, and whether or not the engine is equipped with REDUCTION GEAR or AUXILIARY DRIVE.
- **E.** The last digit indicates the TYPE OF STARTER.

BRIGGS & STRATTON MODEL NUMBERING SYSTEM

A	First Digit After Displacement	Second Digit After Displacement	Third Digit After Displacement	Fourth Digit After Displacement
Cubic Inch Displacement	B Basic Design Series	C Crankshaft Orientation	D PTO Bearing Reduction Gear, Auxiliary Drive, Lubrication	E Type of Starter
6	0	0 to 4 - Horizontal Shaft	0 - Plain Bearing/DU Non-Flange Mount	0 - Without Starter
8	1	5 to 9 - Vertical Shaft	1 - Plain Bearing Flange Mount	1 - Rope Starter
9	2	A to G - Horizontal Shaft	2 - Sleeve Bearing Flange Mounting	2 - Rewind Starter
10	3	H to z - Vertical Shaft	3 - Ball Bearing Flange Mounting	3 - Electric Starter Only 110 or 230 Volt Gear Drive
11	4		4 - Ball Bearing Flange Mounting	4 - Electric Starter/110 or 230 Volt Gear Drive with Alternator
12	5		5 - Plain Bearing Gear Reduction (6-1) CCW Rotation Flange Mounting	5 - Electric Starter Only 12 or 24 Volt Gear Drive
13	6		6 - Plain Bearing Gear Reduction (2-1) CCW Rotation	6 - Alternator Only
16	7		7 - Plain Bearing Pressure Lubrication	7 - Electric Starter 12 or 24 Volt Gear Drive with Alternator
18	8		8 - Plain Bearing Auxiliary Drive (PTO) Perpendicular to Crankshaft	8 - Vertical Pull Starter or Side Pull Starter
19	9		9 - Plain Bearing Auxiliary Drive (PTO) Parallel to Crankshaft	9 - Mechanical Starter
20	A to Z		A - Plain Bearing Pressure Lubrication Without Oil Filter	A - Electric Starter 12 or 24 Volt Gear Drive with Alternator and Inverter
21				
22				
23				
24				
25				
28				
29				
30				
31				
32				
35				
38				
40				
42				
43				
44				
46				
47				
52				
54				
58				

Example - To Identify Model 303447:

30	3	4	4	7
30 Cubic Inch	Design Series 3	Horizontal Shaft	Horizontal Shaft Flange Mounting Pressure Lubrication	Electric Starter 12 or 24 Volt Gear Drive with Alternator

TYPE 1234-01 The type number identifies the engine mechanical parts, color of paint, decals, governed speed and original Equipment Manufacturer.

Code 01061201 The code is the manufacturing date and is read as follows:

Year 01	MONTH 06	DAY 12	ASSEMBLY LINE AND MANUFACTURING PLANT
------------	-------------	-----------	--

ENGINE IDENTIFICATION

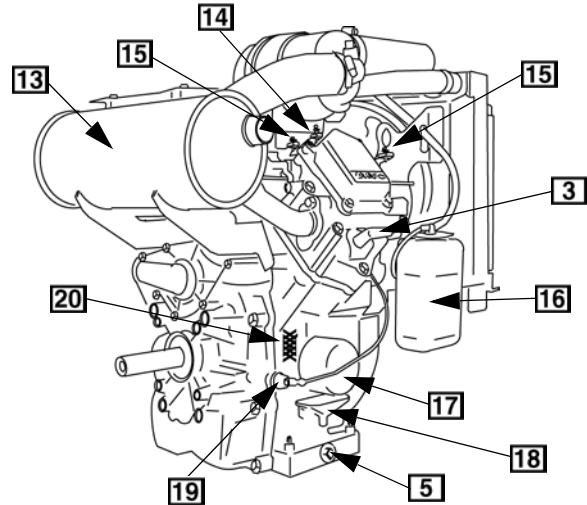
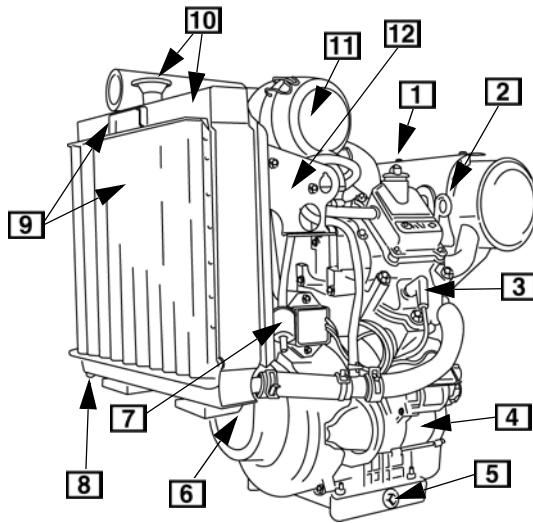

- 1** Oil Fill Cap
- 2** Dipstick
- 3** Spark Plug
- 4** 12V Electric Starter
- 5** Oil Drain Plug
- 6** Fan Belt (If Equipped)
- 7** Fuel Filter
- 8** Radiator Drain Plug (If Equipped)
- 9** Radiator Screen & Handle (If Equipped)
- 10** Radiator & Radiator Cap (If Equipped)
- 11** Air Cleaner (If Equipped)

- 12** Fuel Pump
- 13** Muffler (If Equipped)
- 14** Choke Control
- 15** Throttle Control (2 Possible Locations)
- 16** Radiator Reservoir (If Equipped)
- 17** Oil Filter
- 18** Oil Drip Tray (If Equipped)
- 19** Oil Pressure Switch
- 20** Engine Model Label

MODEL	TYPE	CODE
xxxxxx	xxxx xx	xxxxxxxx

Fig. 1

⚠ DANGER

Unintentional sparking can result in fire or shock.

Unintentional start-up can result in entanglement, traumatic amputation and/or severe lacerations.

- Disconnect the spark plug(s).
- Disconnect the (-) Negative battery cable.
- Use only the correct tools.

SFT-12



MAINTENANCE SCHEDULE

	Daily	50 Hours	100 Hours	250 Hours	600 Hours	Yearly
Check Oil Level	X					
Check For Oil Leaks	X					
Change Oil			X*			
Change Oil Filter			X*			
Check Coolant						
Change Coolant	X					X***
Check Fan Belt			X			
Clean Air Filter			X**			
Replace Air Filter					X**	
Check Valve Clearance				X		
Check Battery Electrolyte				X		
Change Spark Plugs						X
Change Fuel Filter					X	
Clean Spark arrestor		X				

* **Change oil after first 50 hours of use**, then every 100 hours or every season. Change oil every 50 hours when operating the engine under heavy load or in high temperatures.

** Clean more often under dusty conditions or when airborne debris is present. Replace air cleaner parts, if very dirty.

*** If an extended life coolant is used, interval may be increased to once every 3000 hours.



FUEL AND OIL RECOMENDATIONS

Gasoline

Use clean, fresh, unleaded gasoline. Leaded gasoline may be used if unleaded is not available. A minimum of 85 octane is recommended. The use of unleaded gasoline results in fewer combustion deposits and longer valve life.

We do not recommend the use of gasoline that contains alcohol, such as gasohol. However, if used, it must not contain more than 10 percent Ethanol and must be removed from the engine during storage. Do not use gasoline that contains Methanol.

Only purchase a 30-day supply of gasoline. Fresh gasoline minimizes gum deposits and also will ensure fuel volatility tailored for the season in which the engine will be operated.



NOTE: The use of a fuel additive, such as Briggs & Stratton Gasoline Additive (#5041) or equivalent, will minimize the formation of fuel gum deposits during storage. Such an additive may be added to the fuel tank or storage container.

Lubrication

Oil has four purposes. It cools, cleans, seals and lubricates. During normal operation, small particles of metal from the cylinder walls, pistons, bearings and combustion deposits will gradually contaminate the oil. Dust particles from the air also contaminate the oil forming an abrasive mixture which can cause wear to all of the internal moving parts of the engine, if the oil is not changed regularly. Fresh oil also assists in cooling. Old oil gradually becomes thick and loses its cooling ability as well as its lubricating qualities.

Oil Recommendations

Use a high quality detergent oil classified "For Service SF, SG, SH, SJ" or higher. Briggs & Stratton strongly recommends the use of synthetic oil such as Briggs & Stratton (#100074) or equivalent. If synthetic oil is not available, Briggs & Stratton non-synthetic 30 weight oil (#100005 or #100028) is an acceptable substitute. No special additives should be used with recommended oils. Do not mix oil with gasoline.

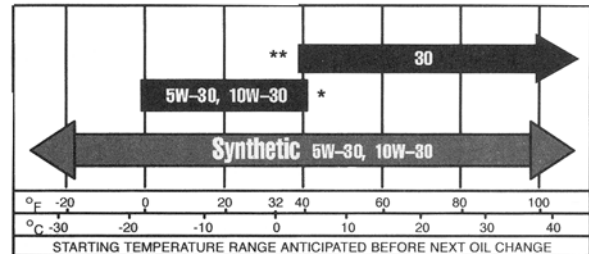

SAE Viscosity Grades



CAUTION: The use of non-synthetic multi-viscosity oils (5W-30, 10W-30, etc.) in temperatures above 405°F (45°C) will result in higher than normal oil consumption. When using a multi-viscosity oil, check oil level more frequently.

SAE 30 oil, if used below 405°F (45°C), will result in hard starting and possible engine bore damage due to inadequate lubrication.

Lubrication System

Briggs & Stratton Vanguard™ liquid cooled OHV V-Twins use a full pressure lubrication system with an oil filter. The gear driven oil pump draws oil from a screened oil pickup and pumps the oil through the oil filter.

The filtered oil flows through oil galleries in the cylinder and crankcase cover and is distributed through the crankshaft to the main bearings and connecting rod bearings. Engine oil pressure will vary with oil viscosity, ambient air temperature differences, operating temperatures and engine load. Follow the oil recommendation shown above.

**Oil Pressure - @ 705° F (215° C): 10 ~ 50 psi
(0.7 ~ 3.5 Bar)**

A pressure relief valve limits the maximum oil pressure in the system.

The engine may be equipped with an oil pressure switch which may be used to activate a warning device if oil pressure drops below approximately 8 psi (.55 Bar). The warning device is supplied by the equipment manufacturer.



CHANGING OIL AND OIL FILTER

Change oil and filter after first fifty (50) hours of operation.

Thereafter, change oil and filter every one hundred (100) hours of operation. Change oil more often if engine is operated in dirty or dusty conditions or if engine is operated under heavy loads or in high ambient air temperatures.

Oil Capacity: Approximately 87 oz. (2.6 liters) with filter.

Place equipment so that engine is level.

1. Remove oil drain plug and drain oil while engine is still warm.
2. Install and torque drain plug to 20 ft. lbs. (27 Nm).
3. Remove oil filter and clean mounting surface.
4. Lightly oil new filter gasket with engine oil.
5. Screw filter on by hand until gasket contacts oil filter adapter. Tighten 1/2 to 3/4 turn more.
6. Clean area around oil fill cap, then remove oil fill cap and add 67 ounces (2 liters) of oil.
7. Start and run engine at idle for 60 seconds. Then, shut engine off and wait 60 seconds.
8. Add more oil slowly to bring oil level to **FULL** mark on dipstick. **Do Not Overfill.**



NOTE: Overfilling can cause a smoking or overheating condition due oil foaming.



9. Replace oil fill cap and dipstick.
10. Start and run engine to check for oil leaks.

CHANGE COOLANT

Coolant should be replaced every year, unless an approved extended life coolant is used. Then replace every 3000 hours.



NOTE: A 50/50 mixture of phosphate-free antifreeze and tap water is required for proper heat dissipation, rust resistance and lubrication.

 DANGER	
	The cooling system is pressurized.
<p>● Do not remove the radiator cap while the engine is hot. To avoid scalding hot coolant or steam from blowing out of the radiator, use extreme care when removing the radiator cap. If possible, wait for engine to cool. Wrap a thick rag around radiator cap while removing. To release pressure, slowly turn cap counter-clockwise to the first stop. When all pressure has been released, press down on cap and continue turning.</p>	
SFT-11	



CAUTION: Used coolant is a hazardous waste product. Dispose of used coolant properly. Check with your local authorities, service center, or dealer for safe disposal/recycling facilities.

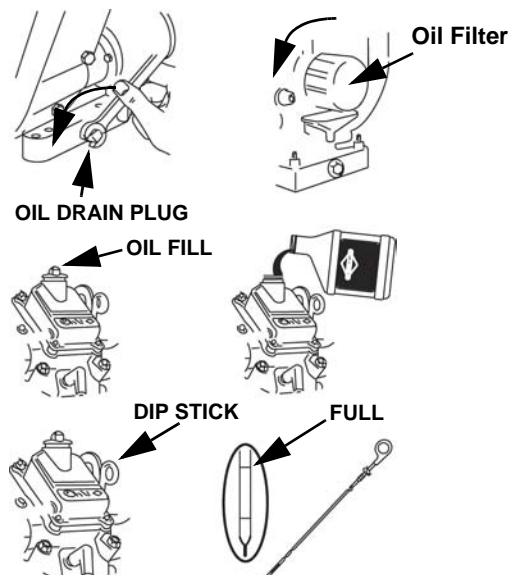

1. Remove drain plug. As coolant is running out, open radiator cap to allow any trapped coolant to drain. Replace drain plug.
2. Remove reservoir bottle, drain it and reinstall.
3. Fill radiator to bottom of filler neck and between **FULL** and **LOW** in reservoir. Replace radiator cap.
4. Start and run engine for 30 seconds.
5. Shut engine off and allow it to cool. Recheck coolant levels in radiator and reservoir.
6. Coolant level in reservoir bottle should be between **FULL** and **LOW** when engine is cold.

Fig. 2

Normal coolant temperature gauge (if equipped) should read between 175° and 195° F (80° and 90° C) when engine is running.

If coolant temperature rises above 220° F (105° C), the temperature light (if equipped) will illuminate. Idle engine down for a while. Then stop engine. Once engine is cooled, check coolant level, fan belt tension and clogged radiator fins.

CLEANING DEBRIS

Daily or before every use, clean accumulated debris from engine. Keep linkage, springs and controls clean. Keep area around and behind muffler free of any combustible debris.

Use the handle on the radiator screen to lift off for cleaning. Clean screen thoroughly and clean radiator fins.

Do not use water to clean engine parts. Water could contaminate fuel system. Low pressure compressed air may be used. Be careful not to damage radiator fins.



CAUTION: Engine parts should be kept clean to reduce the risk of overheating and ignition of accumulated debris

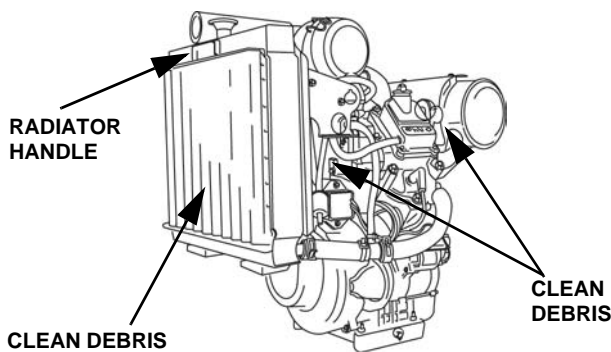

Fig. 3

ADJUST FAN BELT

- Check condition of fan belt.
- Replace if damaged or worn.

To Adjust Fan Belt Tension

1. Loosen bolt **1** and bolt **2**.
2. Fit torque wrench in the square hole located in the bracket.
3. Apply 115 in. lbs. of torque in the direction of the arrow.
4. While belt is being tensioned per step 3, torque bolt **1** to 125 in. lbs. (14 Nm). Torque bolt **2** to 110 in. lbs. (12 Nm).

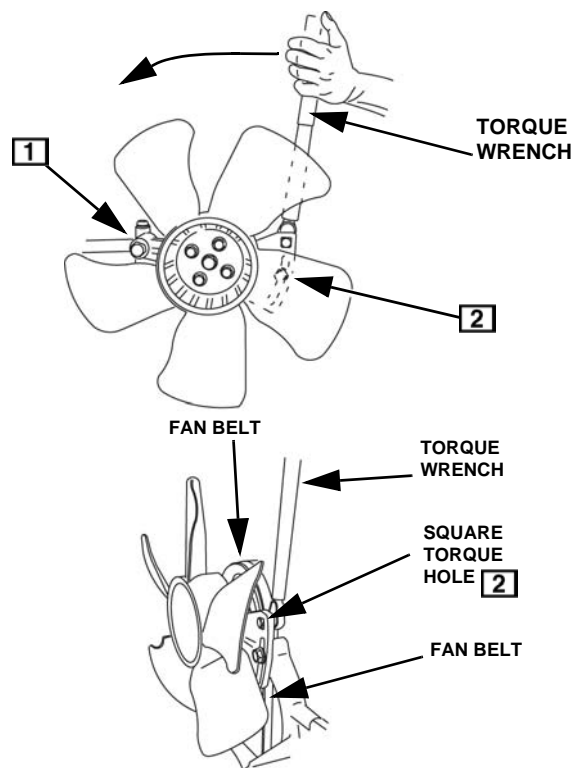

Fig. 4

AIR CLEANER MAINTENANCE



WARNING: Never operate engine with air cleaner assembly or air cleaner cartridge removed.

A properly serviced air cleaner protects internal parts of the engine from dirt and dust particles in the air. If air cleaner instructions are not carefully followed, dirt and dust which should be collected in the cleaner will be drawn into the engine. These particles are highly abrasive and will cause the piston rings and cylinder



bore to wear quickly. As the rings and cylinder bore become worn, these abrasive particles enter the crankcase and contaminate the oil, forming an abrasive mixture which will cause wear on all of the internal moving parts.

Clean cartridge every 100 hours. To clean cartridge, gently tap on end with handle of screwdriver. Replace cartridge every 600 hours. Clean and replace more often under dusty conditions. Replace if very dirty or any damage occurs to cartridge.



NOTE: Do not use pressurized air or solvents to clean cartridge. Pressurized air can damage cartridge; solvents will dissolve cartridge.

1. Unlock clamps **1** and remove cover **2**.
2. Remove cartridge **3** from air cleaner body.
3. Carefully clean out air cleaner cover.
4. Install cartridge in body.
5. Install cover and lock clamps with rubber valve down.

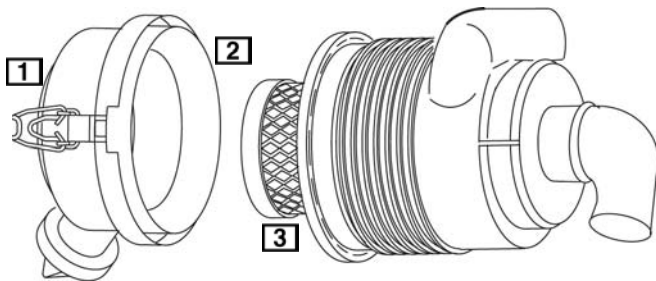

Fig.5

REPLACE SPARK PLUG

Replace spark plugs every year. Replace spark plugs if electrodes are burned away, or the porcelain is cracked. Set spark plug gap at .020" (.51 mm). Torque spark plugs to 180 in. lbs. (20.0 Nm).

B&S to Champion*

Plug Type	B&S	Champion*
Resistor Plug	491055	RC12YC
Resistor Plug	496018	RC14YC

* Champion and the Bow Tie are trademarks of Federal-Mogul Ignition Co. Used under license.



NOTE: Do not blast clean spark plugs. Spark plugs should be cleaned by scraping or hand wire brushing and washing in a commercial solvent.

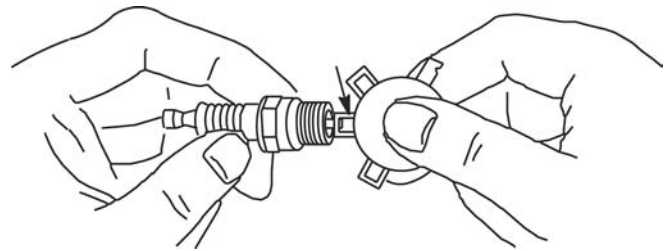

Fig. 6



OTES

A large grid of dotted lines for taking notes, consisting of approximately 20 columns and 30 rows.

SECTION 2 TROUBLESHOOTING

GENERAL INFORMATION

Most complaints concerning engine operation can be classified as one or a combination of the following:

1. Will not start
2. Hard Starting
3. Lack of power
4. Runs Rough
5. Vibration
6. Overheating
7. High Oil Consumption



NOTE: What appears to be an engine malfunction may be a fault of the powered equipment rather than the engine. If equipment is suspect, see Equipment Affecting Engine Operation.

WILL NOT START

Engine Will Not Turn Over

1. Make sure that safety equipment installed by the Original Equipment Manufacturer (OEM) is functioning properly and is not preventing the engine from cranking. Remove any parasitic load on engine (drive unit disengaged).
2. Make sure battery cables and solenoid connections are clean and tight.
3. Check battery voltage from positive battery terminal to battery terminal on solenoid.

Voltage must not be below 11.7 volts.

Check Starter

A jumper wire is required for the next test.

1. Disconnect wire at tab terminal on solenoid.
2. Attach one end of jumper wire to positive terminal on battery. Then, make contact to tab terminal **1** on solenoid, Fig. 7.

3. If starter cranks, there is a problem with the key switch or wiring.

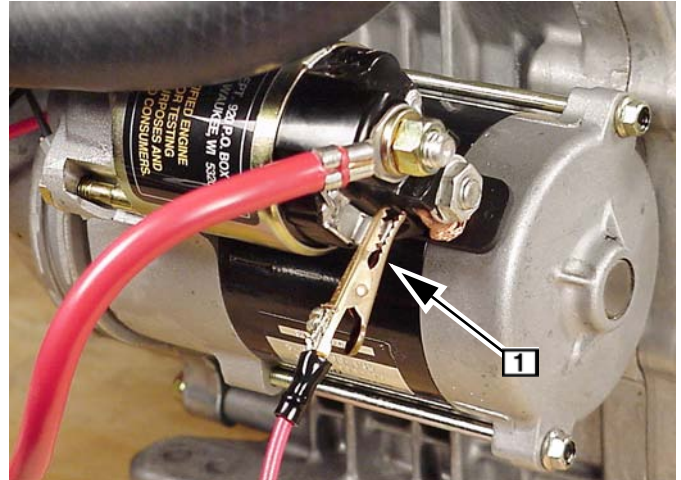

Fig. 7

4. If starter does not crank, remove jumper wire from battery and attach to battery terminal **2** on solenoid.
5. With other end of jumper wire, make contact to the field terminal **3** on solenoid, Fig. 8.

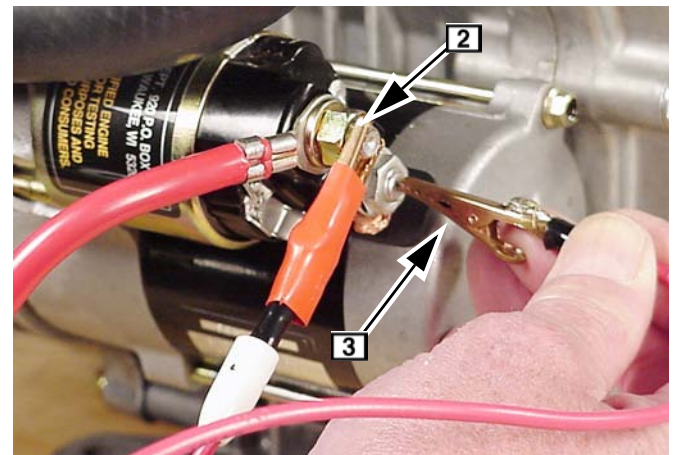

Fig. 8

6. If starter turns over, the solenoid is defective. Replace solenoid.

If starter does not turn over, the starter motor is defective. Replace starter motor.

Engine Turns Over Slowly

If engine turns over slowly, but will not start, first refer to **Will Not Start**, steps 1 - 3. Then perform a starter current draw test.

STARTER CURRENT DRAW TEST

IMPORTANT: When making the starter current draw test make sure that all parasitic load is removed from the engine and that engine has the correct viscosity oil. Engine temperature should be at least 70°F (21°C).

Make sure battery and solenoid connections are clean and tight.



NOTE: Battery voltage must not be below 11.7 volts.

Test Equipment

The following equipment is required to test current draw of starter, Fig. 9.

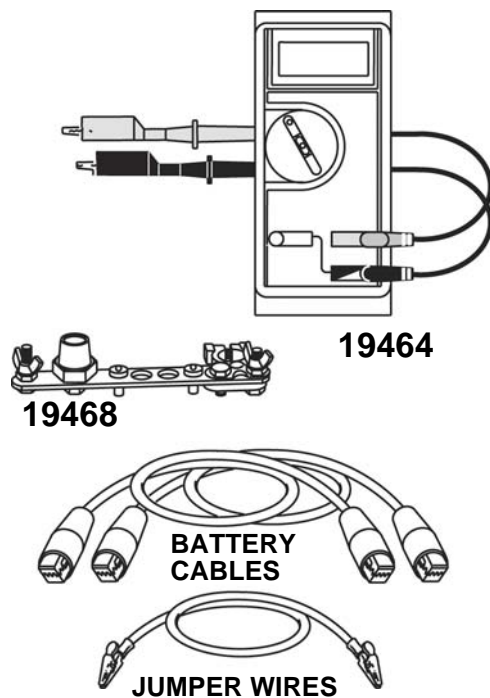

Fig. 9

1. Digital multi-meter, Tool #19464.
2. DC shunt, Tool #19468.
3. Two battery cables with alligator clips.
4. One jumper wire with alligator clips.

5. A fully charged 12 volt battery.

Testing Starter



NOTE: To prevent engine from starting, remove spark plug wires from spark plugs and ground ignition using two Ignition Testers, Tool #19368. Leave spark plugs installed.

The starter current draw test will be performed with the meter in the **300mV** position.

The DC Shunt must be installed on the negative (-) terminal **1** of the battery, Fig. 10.

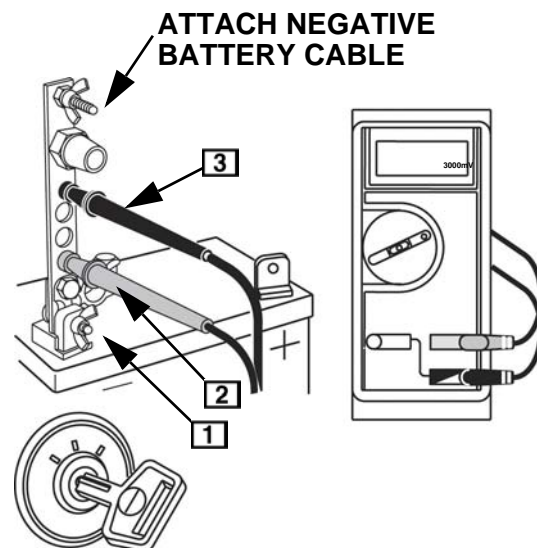

Fig. 10

1. Attach **RED 2** meter test lead to **RED** post terminal on shunt.
2. Attach **BLACK** meter test lead **3** to **BLACK** post terminal on shunt.
3. Activate starter.
 - a. Allow 3 seconds for meter reading to stabilize.
4. Current draw should not exceed 80 amps DC.

If amperage draw exceeds specification, remove starter from engine and perform No Load starter current draw test.

NO LOAD STARTER CURRENT DRAW TEST

Remove starter motor.

To hold starter securely while testing, clamp starter mounting bracket in a vise. DO NOT clamp starter housing in a vise or field windings or magnets may be damaged.

Testing Starter (No Load)

The No Load starter current draw test will be performed with the meter in the 300mV position.

The DC Shunt must be installed on the negative (-) terminal of the battery, Fig. 11.

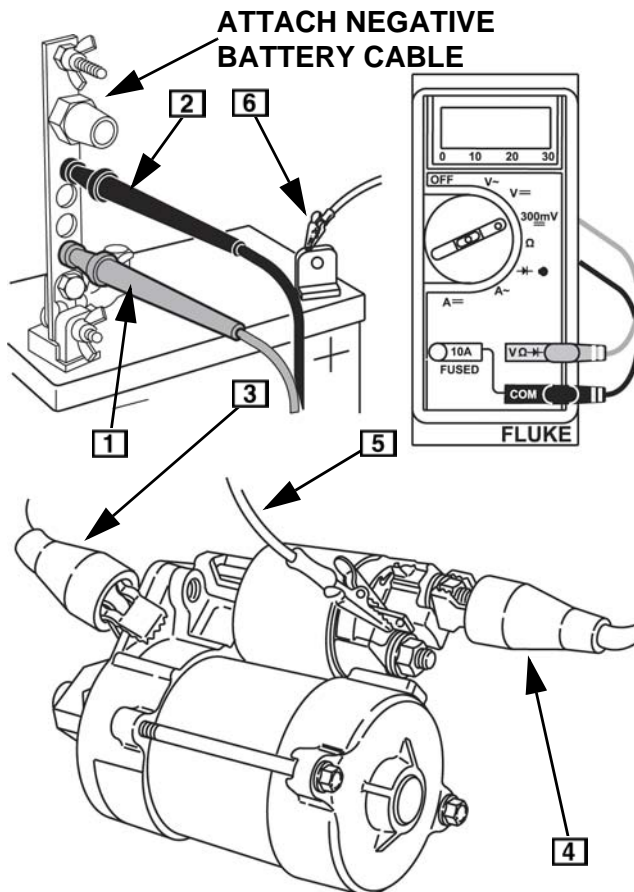

Fig. 11

1. Attach **RED** meter test lead **1** to **RED** post terminal on shunt.
2. Attach **BLACK** meter test lead **2** to **BLACK** post terminal on shunt.

3. Attach negative battery cable **3** to a good ground such as drive housing.
4. Attach positive battery cable **4** to battery terminal on solenoid.
5. Attach one end of jumper wire **5** to solenoid tab terminal, Fig. 11.
6. Activate starter by contacting positive battery terminal with other end of jumper wire **6**, Fig. 11.
 - a. Allow 3 seconds for meter reading to stabilize.
7. Current draw should not exceed 50 amps DC.

If amperage draw exceeds specification, replace starter.

Hard Starting

Make sure the oil level is correct.

This engine is equipped with a “Low Oil Pressure Sensor” and will not start if the oil level is too low.

Make sure drive unit is disengaged.

A loose drive belt like a loose blade can cause a backlash effect, which will counteract engine cranking effort.



NOTE: Magnetron® ignition system requires a minimum of 350 RPM before it will produce a spark.

Systematic Check

If the engine is hard starting or will not start and the cause of malfunction is not readily apparent, perform a systematic check in the following order:

1. Ignition
2. Carburetion
3. Compression

This check-up, performed in a systematic manner, can usually be done in a matter of minutes. It is the quickest and surest method of determining the cause of failure.

Check Ignition (With Engine Starter)

With spark plugs installed, attach a #19368 ignition tester to each spark plug lead and ground the other end of the tester as shown in Fig.12. Activate the electric starter. If spark jumps the tester gaps, you may assume the ignition system is functioning satisfactorily.

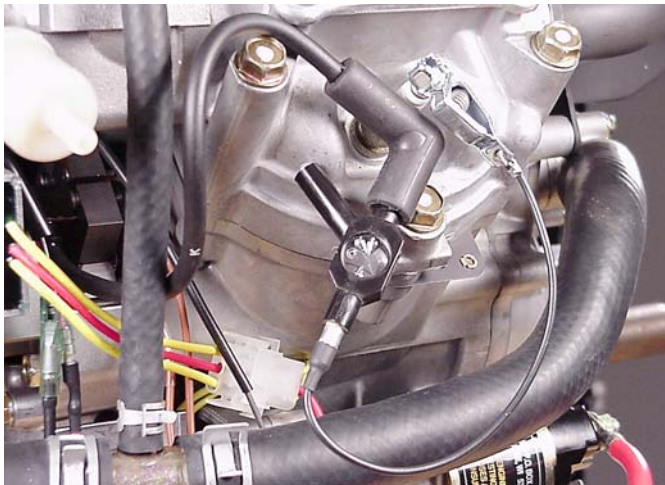

Fig. 12



NOTE: Engines equipped with Magnetron® ignition system will still display spark at tester with a partially or fully sheared flywheel key. A partially sheared flywheel key will affect ignition timing and engine performance.

WARNING	
	<p>On Magnetron® equipped engines, spark can still occur with a sheared flywheel key. A severe shock or kickback hazard may exist.</p>
<p>● Ground the magneto to the case to prevent accidents.</p>	
<small>SFT-13</small>	

If spark does not occur look for:

1. Improperly operating interlock system
2. Shorted equipment stop switch wire
3. Two closed diodes in ground wire harness (see: Troubleshooting Ground Wire Harness)
4. Incorrect armature air gap
5. Armature failure

Check Ignition (Engine Running)

If engine runs but misses during operation, a quick check to determine if ignition is or is not at fault can be made by installing Tool #19368 tester between the spark plug lead and each spark plug, Fig.13. A spark miss will be readily apparent when the engine is running. If spark is good but engine misses, check for a fouled spark plug.

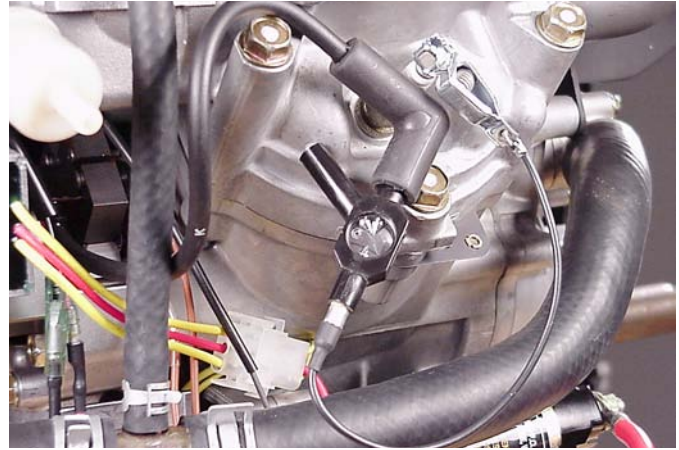

Fig. 13

Check Ignition (Fouled Plug or Other Causes)

To check for a fouled spark plug or a non-functioning cylinder, attach Tool #19368 tester between the spark plug lead and each spark plug. With engine running at top no load speed, ground one spark plug, Fig. 14. The engine should continue to run on the other cylinder. Repeat this test with the other cylinder. If the engine will not continue to run when making this test, the cylinder that is NOT grounded is not functioning and/or the spark plug is fouled. Install a new spark plug before proceeding. When replacing spark plugs always use Briggs & Stratton #491055 or #496018.



Fig. 14

If miss continues:

The problem may be carburetion or compression related. See Check Carburetion and/or Cylinder Balance Test and Cylinder Leakdown Test.

Troubleshooting Ground Wire Harness

The ground wire harness contains two diodes. If a diode fails “open,” the cylinder with the open diode will continue to run when the equipment key switch is turned off. If a diode fails “short,” the cylinder with the shorted diode will not run (no spark).

Refer to Failure Diagnosis Table for symptoms.

Testing Ground Wire Harness

The Digital Multimeter, Tool #19464 is recommended to test the ground wires. The following test will be made with the meter in the “Diode Test Position”.

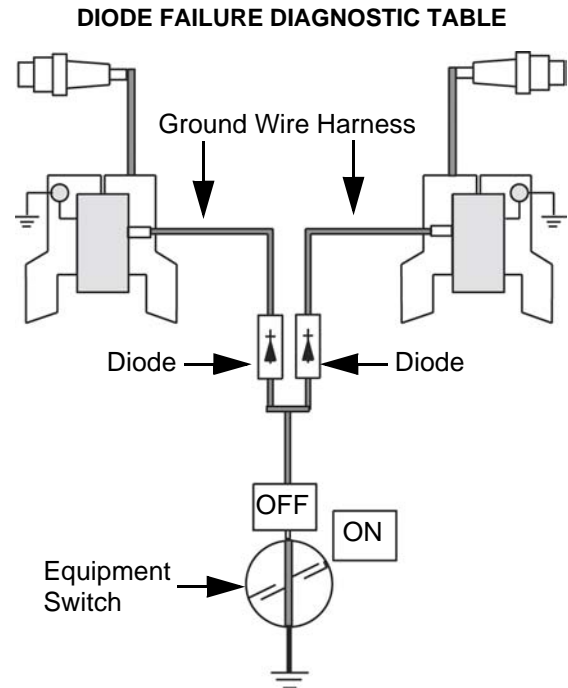

SWITCH ON	SWITCH OFF	CAUSE
Engine runs on one cylinder.	Shuts Off OK	1 Closed Diode
Engine runs. (Both Cylinders)	Only one cylinder shuts Off	1 Open Diode
Won't Run (No Spark)		2 Closed Diodes
Engine runs. (Both Cylinders)	Engine won't shut Off	2 Open Diodes

Fig. 15

In the Diode Test position, the meter will display the forward voltage drop across the diode(s). If the voltage drop is less than 0.7 volts, the meter will “Beep” once as well as display the voltage drop. A continuous tone indicates continuity (shorted diode). An incomplete circuit (open diode) will be displayed as “OL.”

1. Insert **RED** test lead into receptacle in meter.
2. Insert **BLACK** test lead into receptacle in meter.
3. Rotate selector to (Diode Test) position.
4. Insert **RED** test lead into ground wire terminal (brown wire) **1** receptacle in engine harness, Fig. 16. Leave attached for remainder of test.
5. Touch **BLACK** test lead probe to ground wire tab terminal on ignition coil for #2 cylinder.

If meter “Beeps” once, diode is OK.

If meter makes a continuous tone, diode is defective (shorted). Replace ground harness.

If meter displays “OL,” diode is defective (open). Replace ground harness.

6. Now, repeat test for #1 cylinder. Results must be the same.

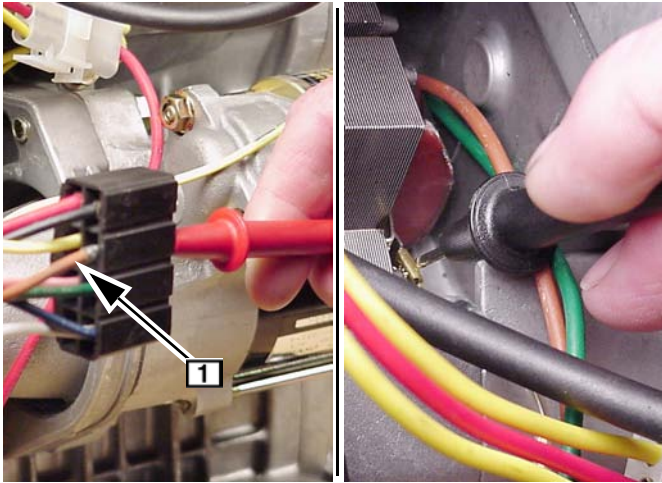

Fig. 16

CHECK CARBURETION

Before making a carburetion check, be sure the fuel tank has an ample supply of fresh, clean gasoline. Be sure that the shutoff valve, if equipped, is open and fuel flows freely through the fuel line before starting engine.

If fuel fails to flow or is slow check for plugged fuel cap vent, fuel line restriction or plugged fuel filter.

Make sure throttle and choke controls are properly adjusted.

If engine cranks but will not start, remove and inspect the spark plugs.

If plugs are wet, look for:

1. Over choking
2. Excessively rich fuel mixture
3. Water in fuel
4. Float needle valve stuck open
5. Plugged air cleaner
6. Fouled spark plugs

If plugs are dry, look for:

1. Leaking carburetor or intake manifold mounting gaskets
2. Gummy or dirty carburetor, fuel filter, fuel lines or fuel tank
3. Float needle valve stuck shut
4. Inoperative fuel pump
5. Inoperative fuel shut off solenoid

A simple check to determine if the fuel is getting to the combustion chamber through the carburetor is to remove either spark plug and pour a small quantity of gasoline through the spark plug hole. Replace the plug. If the engine fires a few times and then stops, look for the same conditions as for a dry plug.

FUEL SHUT-OFF SOLENOID

The fuel shut off solenoid is controlled by the equipment ignition switch. When the equipment switch is in the **OFF** position, the solenoid valve plunger closes, stopping fuel flow through the fixed main and idle jets. When the switch is in the **ON** and **START** position, the solenoid valve opens, allowing normal fuel flow. The solenoid is operating properly if a click is heard when equipment ignition switch is turned **ON** and **OFF**. If solenoid is not working (defective solenoid or equipment wiring), the engine will not start or run.



NOTE: Fuel shut off solenoid requires a minimum of 9 volts DC to function.

Testing Solenoid

If solenoid does not click, the problem may be in equipment wiring, engine wiring harness or solenoid. To determine whether problem is with wiring or solenoid, perform the following tests in the order shown.

Test Equipment

The digital multimeter, **Tool #19464** is required to test the solenoid equipment wiring.

The following tests will be performed with the meter in the (DC volts) position.

Testing Equipment Wiring

1. With keyswitch in **OFF** position, disconnect solenoid wire (GRAY WIRE) from engine wiring harness connector (WHITE WIRE).
2. Insert red meter test lead into equipment side of wiring harness connector (WHITE WIRE) **1**, Fig. 17.
3. Attach black test lead to a good ground **2**.
4. Turn keyswitch to **ON** position.
 - a. Meter should display battery voltage at connector.

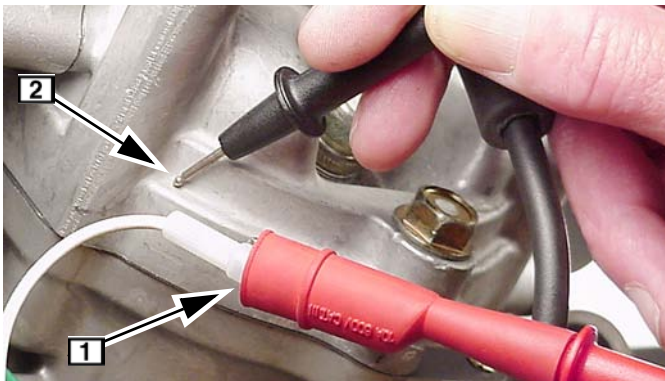

Fig. 17

If meter does not display battery voltage, problem is with wiring harness. Check for loose or broken wire.

If meter displays battery voltage, test engine wiring harness.

Testing Solenoid

A pair of jumper wires and a 9 volt transistor battery are required for this test.

1. Attach one jumper wire to solenoid wire **1** (GRAY WIRE) and positive terminal on battery **1**, Fig. 18.
2. Attach second jumper wire to negative terminal on battery **2** and a good ground **2**.
3. Solenoid should “click”.

4. If solenoid does not “click”, it is defective. Replace.

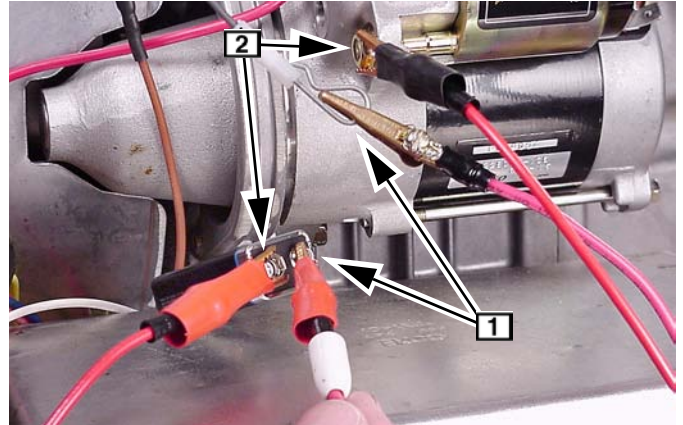

Fig. 18

FUEL PUMP - GENERAL INFORMATION

The fuel pump, mounted on the No. 1 cylinder fan bracket, allows remote fuel tank installations. The fuel pump will prime at 12” (30.5 cm) maximum lift. Fuel pump pressure is 1.5 psi (0.1 Bar). The pump is operated by pulsating crankcase vacuum from the engine. The vacuum pulse line is installed on the No. 1 cylinder valve cover, Fig. 19.

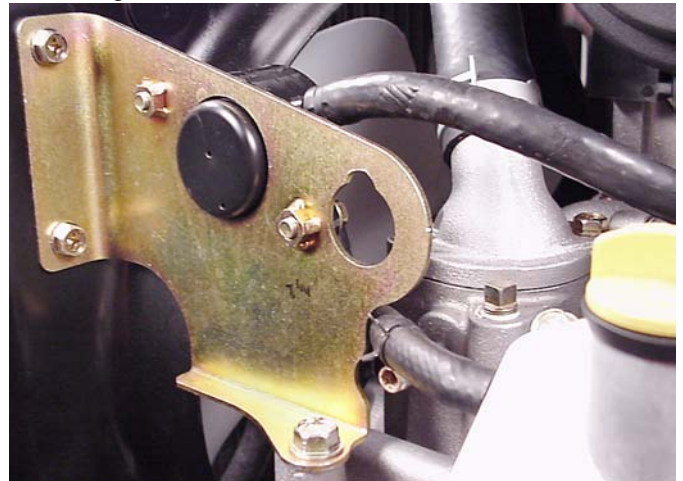

Fig. 19

NOTE: An air leak at the fuel pump pulse line hose connections will result in improper fuel flow. The fuel pump is available as an assembly only.

Replace fuel lines and vacuum pulse line if stiff and brittle.

CYLINDER BALANCE TEST

If the engine is hard starting, runs rough, misses or lacks power, perform a cylinder balance test to determine whether both cylinders are operating to their full potential.

Tools Required

1. Tachometer, **Tool #19200 or 19389**
2. Two **#19368** Ignition Testers
3. Screwdriver with insulated handle

Attach ignition tester, **Tool #19368** between the spark plug lead and each spark plug, Fig. 20.

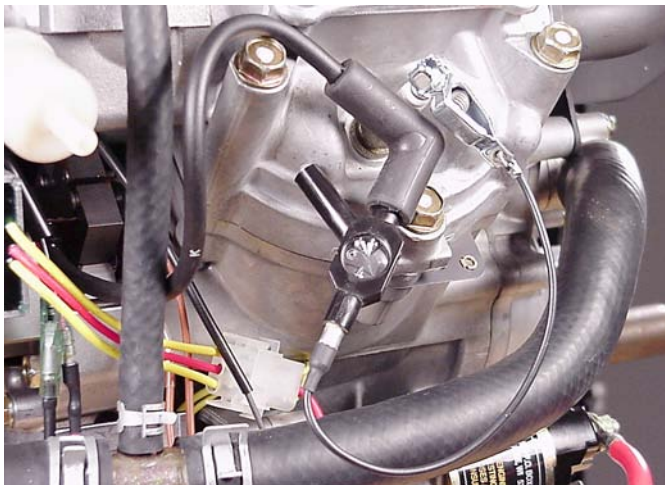

Fig. 20

Start and run engine running at top no load speed and note spark at ignition testers. If the spark is equal at both ignition testers, the problem is not ignition related. A spark miss will be readily apparent. Now note RPM of engine. Ground out one cylinder with screwdriver by contacting alligator clip on ignition tester and a good ground on engine, Fig. 21. Note RPM loss. Then ground out the other spark plug and note the RPM loss. If the difference between the two cylinders does not exceed 75 RPM, the amount of work the two cylinders are doing should be considered equal.



Fig. 21

Things Which Affect Both Cylinders

1. Carburetion
2. Crankcase vacuum
3. Ignition timing
 - a. A partially sheared flywheel key will affect ignition timing and engine performance.

If the RPM loss is greater than 75 RPM this indicates that the cylinder with the least RPM loss is the weaker of the two cylinders. Look to that cylinder for a problem.

Example:

Engine RPM - Both Cylinders = 3400 RPM

Engine RPM - #1 Cylinder Grounded = 3300 RPM

Engine RPM - #2 Cylinder Grounded = 3100 RPM

Conclusion: #1 cylinder is the weaker of the two cylinders.

Things Which Affect One Cylinder

1. Spark plug
 - a. A fouled spark plug may indicate that carburetor is out of adjustment.
2. Leak in spark plug wire
3. Head gasket
4. Intake manifold
 - a. A leak at either end of the intake manifold will only affect one cylinder, not both.
5. Valves
6. Rings
7. Piston
8. Cylinder

The cylinder balance test will also detect a cylinder that is not functioning. When grounding out one cylinder

there will be no RPM loss. When the other cylinder is grounded out the engine will stop.



NOTE: A twin cylinder engine will run well on one cylinder as long as the power required for the application does not exceed the power produced by the one cylinder.

CYLINDER LEAKDOWN TEST

An accurate method of checking the sealing capability of the compression components is by using the cylinder leakdown tester **Tool# 19545**. The leakdown test will show any variation between cylinders as well as identify which components may be at fault.

A regulated amount of compressed air is used to pressurize the combustion chamber with the piston at TDC on the compression stroke. By listening for air leaks, it is possible to isolate a specific component or components causing a problem. An engine in good condition will display a reading in the green area on the outlet gauge with a minimum of audible leakage. A reading in the yellow or red area along with high audible leakage indicates a problem with the compression components.

A small amount of air leakage is normal in all engines, including new engines, providing that the outlet gauge remains in the green area.

However, if a single component is displaying more audible leakage, look to that component for a potential problem. For example, frequently a slight air leak at the head gasket may not register on the gauge. Obviously the head gasket would require replacement, as any leak at the head gasket would have an adverse affect on engine performance.



NOTE: When testing water cooled engines, always remove the radiator cap. If air bubbles are observed in the coolant while the combustion chamber is pressurized, this indicates that the head gasket is leaking internally and/or the cylinder head or block is cracked.

Compression Testing Using Leakdown Tester, Tool #19545

1. Run engine for 5 minutes allowing engine to reach operating temperature.



NOTE: If engine is cold or cannot be started, air flow may be higher (gauge readings lower)

because compression components are not at normal operating temperatures.

2. Remove spark plugs from engine. Disconnect air cleaner tube and crankcase breather tube at carburetor intake elbow.
3. Rotate crankshaft in direction of operation until piston for cylinder being tested is at top dead center of compression stroke.
4. Assemble the clamping tool to the crankshaft. Torque screws to **150 in. lbs.** Insert drive end of a 3/8" breaker bar into slot of clamp or install screw through slot into bolt circle hole in crankcase cover, Fig. 22.

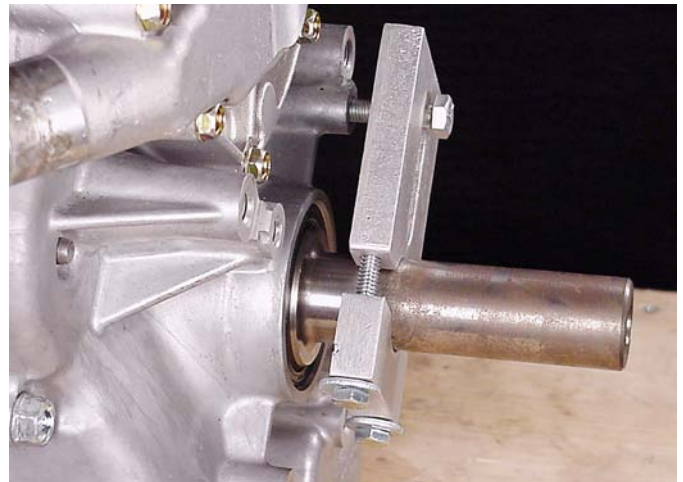
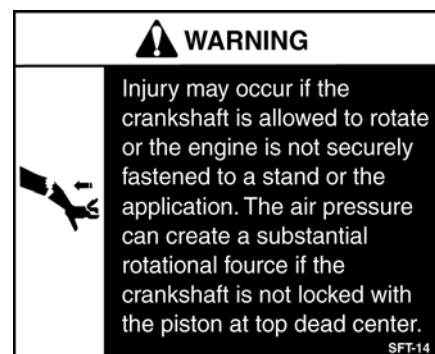

Fig. 22



NOTE: The crankshaft must be held with the piston at top dead center to seal the combustion chamber and eliminate any chance of rotation. If the engine is installed in an application, many times the equipment can positively lock the crankshaft from moving.



5. Pull the regulator adjustment knob **1** out and turn knob counterclockwise as far as it will go, Fig. 23. Make sure air outlet valve **2** is closed.

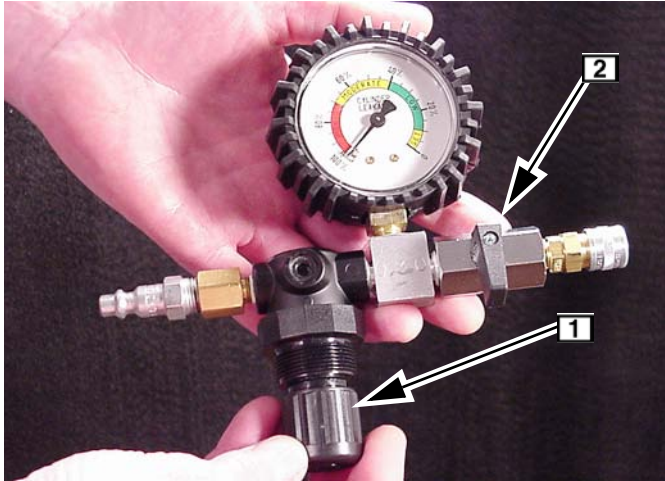

Fig. 23

6. Connect the tester to the shop air source (minimum air pressure of 70 psi).
7. Install the outlet hose into the spark plug hole of the cylinder being tested. Be sure “O” Ring is seated to prevent air leak at spark plug hole. Connect other end to tester.
8. Turn regulator adjustment knob clockwise until the tester’s needle is on the set point. Push knob in to lock. Slowly open air outlet valve and note position of needle on gauge, Fig. 24.

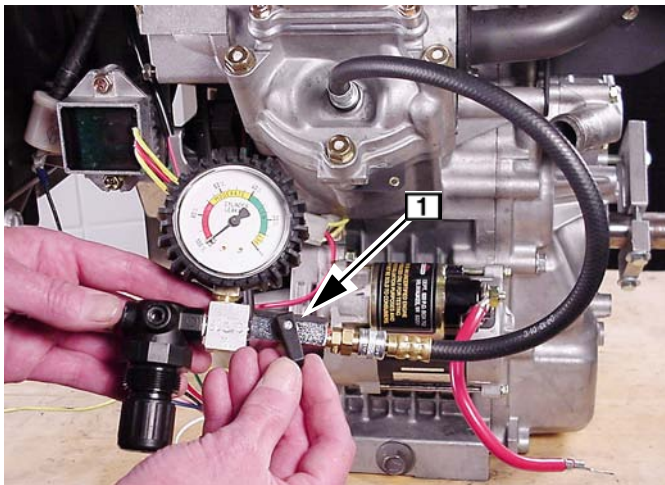

Fig. 24



NOTE: Any air leaks at the connections or fittings of the tester will affect the accuracy of the test.

9. Listen for air leaking from the cylinder head gasket, carburetor, exhaust system and the crankcase breather tube.



NOTE: If a high flow of air is leaking from the exhaust and carburetor, make sure the piston is at TDC on the compression stroke.

- a. Air flowing between the cylinder and cylinder head indicates that the cylinder head gasket is leaking.
- b. Air flowing from the carburetor indicates air is leaking past the intake valve and seat.
- c. Air flowing from the exhaust system indicates air is leaking past the exhaust valve and seat.
- d. Air flowing from the crankcase breather tube or high oil fill dipstick tube indicates air is leaking past the piston rings.

COMPRESSION TEST RESULTS

Reading is Green. A small amount of air is leaking from head gasket.	Replace head gasket, and re-test.
Reading is Green. Minimum air leakage.	Look for problems that are not compression related.
Reading is Yellow/Red or Red, and all the air is leaking from one component.	Look for a possible problem with that component.
Reading is Red, and air is leaking from several components.	Check that piston is at TDC on the compression stroke. If reading does not change, look for problems beginning with the component that appeared to leak the most air. Re-test after repair.

10. When test is complete, close air valve. Then, pull out knob and turn counterclockwise as far as it will go to release pressure in combustion chamber.



11. Disconnect outlet hose from tester before removing from spark plug hole.
12. Repeat test for other cylinder.

The variation between the two cylinders should be less than 20%. If the difference is greater than 20%, check the cylinder with the lower reading.

Possible Causes for Poor Compression:

1. Loose cylinder head bolts
2. Blown head gasket
3. Burned valves, valve seats and/or loose valve seats
4. Insufficient tappet clearance
5. Warped cylinder head
6. Warped valve stems
7. Worn bore and/or rings
8. Broken connecting rods

CHECKING COOLING SYSTEM

 DANGER	
	The cooling system is pressurized.
<p>● Do not remove the radiator cap while the engine is hot. To avoid scalding hot coolant or steam from blowing out of the radiator, use extreme care when removing the radiator cap. If possible, wait for engine to cool. Wrap a thick rag around radiator cap while removing. To release pressure, slowly turn cap counter-clockwise to the first stop. When all pressure has been released, press down on cap and continue turning.</p>	
<small>SFT-11</small>	

Pressure Testing Cooling System

1. Remove radiator cap and make sure coolant is at correct level, Fig. 25.

- a. Coolant level must be no more than 1 in. (.25 mm) below bottom of filler neck.



Fig. 25

2. Install cooling system pressure tester on radiator and pressurize system to **15 psi (1.03 Bar)**.



NOTE: System must maintain pressure during test.

3. Check the following for any signs of leaking.
 - a. Hoses and connections (also check hoses for excessive bulging)
 - b. Radiator
 - c. Water pump
 - d. Telltale hole in crankcase cover
 - e. Intake manifold and by-pass hose
 - f. Cylinder block and cylinder head



NOTE: If coolant is evident at the telltale hole **1** in the crankcase cover, Fig. 26, this is an indication that the water pump seal in the crankcase cover is leaking, which may cause coolant to enter the crankcase and contaminate the oil. Severe engine damage could occur.



Fig. 26

The water pump seal is replaceable. See Section 4. If system does not maintain pressure and no leaks are evident externally, there may be an internal leak such as a blown head gasket, warped cylinder head or cylinder block.

Testing Radiator Cap

Make sure that rubber seal on radiator cap is not damaged or distorted. Rubber seals must be clean and free of debris to seal properly.

1. Install radiator cap on pressure tester and pressurize the cap.

Specification: 11 ~ 15 psi (0.75 ~ 1.03 Bar)

Replace cap if not within specification.



NOTE: Recommended pressure cap capacity is **13 psi (0.9 Bar)**.

Checking Thermostat

A thermometer capable of reading **212° F (100° C)** or more is required.

1. Check to make sure thermostat valve is fully closed.
2. Immerse thermostat in water and heat water gradually, Fig. 27.
3. Note temperature when thermostat starts to open.
 - a. **178 ~ 183° F (81 ~ 84° C)**
4. Note temperature when thermostat is fully open.
 - a. **203° F (95° C)**

5. Remove thermostat from water and allow it to cool.
 - a. Thermostat should close fully.

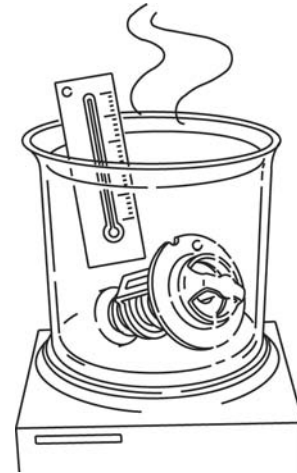

Fig. 27

CHECK OIL PRESSURE SWITCH

Use Digital multimeter, **Tool #19464**. Set meter to test for continuity.

Remove pressure switch for testing. Connect one continuity tester lead to the switch terminal and the other tester lead to the metal body of the switch, Fig. 28. The tester should indicate continuity when no pressure is applied to the switch. The switch should open (no continuity) when approximately 8.0 psi (0.55 Bar) is applied. Replace the switch if test results are not to specification.

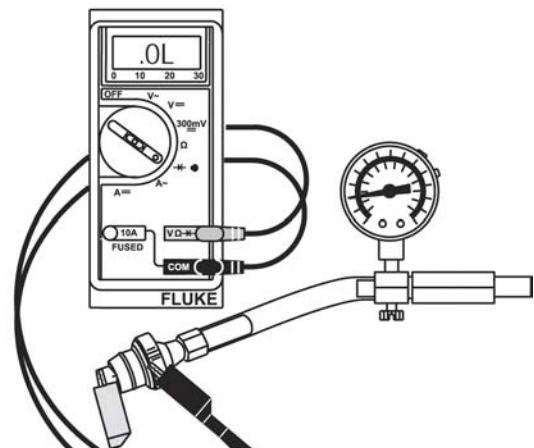

Fig. 28

CHECK OIL PRESSURE

1. Oil level must be between the **LOW** and **FULL** mark on dipstick. If oil level is low, check for leaks and add to **FULL** mark.
2. Remove pressure switch.
3. Install oil pressure gauge, Fig. 29.
4. Start and run engine for approximately 5 minutes.
5. Check oil pressure at 3000 RPM.

Oil Pressure - @ 70°F (21°C): 10 ~ 50 psi (0.7 ~ 3.5 Bar)

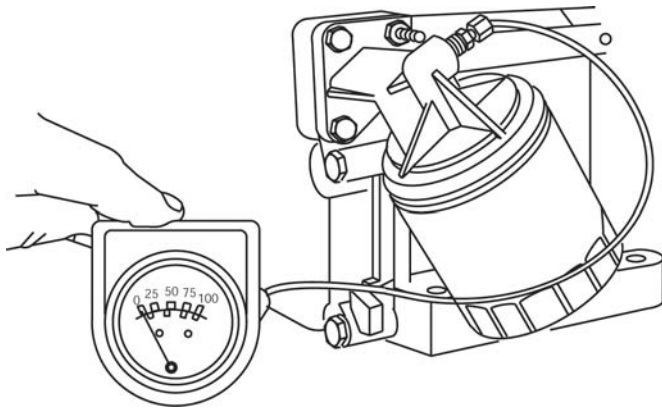

Fig. 29

Low Oil Pressure could be caused by:

- Engine RPM Too Low
- Wrong Viscosity or Diluted Oil
- Low Oil Level
- Broken Pressure Relief Spring
- Missing Pressure Relief Plunger
- Leaking O-Ring in Crankcase Cover
- Worn Bearings
- Damaged or Defective Oil Pump

High Oil Pressure could be caused by:

- Wrong Viscosity Oil
- Plugged Oil Galleries
- Stuck Pressure Relief Plunger

CHARGING SYSTEM

The engine is equipped with a 20 amp regulated alternator system that provides AC current through two output leads to the regulator-rectifier. The regulator-rectifier converts the AC current to DC, and regulates current to the battery. The charging rate will vary with engine RPM and temperatures.

The stator, regulator-rectifier and flywheel are not interchangeable with any other alternator system.

TROUBLESHOOTING

The following list is provided to aid you in diagnosing the possible causes of problems with alternator systems.

“Battery not charging”

- Inline fuse “blown” (if equipped).
- Defective battery.
- Loose, pinched, or corroded battery leads.
- Open, shorted, or grounded wires between output connector and battery.
- Defective diode (open or shorted).
- Defective or improperly grounded regulator-rectifier.
- Damaged battery (shorted battery cells).
- Excessive current draw from accessories.
- Low magnetic flux or damaged alternator magnets.
- Engine RPM too low.

“Battery in state of overcharge”

- Severe battery vibration (missing or broken tie-down straps)
- Battery rate of charge not matched to alternator output
- Damaged battery (shorted battery cells)
- Defective regulator

Testing Alternator Output

WHEN CHECKING THE ALTERNATOR COMPONENTS, MAKE THE TESTS IN THE FOLLOWING SEQUENCE:

1. Insert **RED** test lead into **V** receptacle in meter.
2. Insert **BLACK** test lead into **COM** receptacle in meter.
3. Rotate selector to AC volts position.

CAUTION: Attach meter test leads to AC output terminals in white connector (yellow wires) BEFORE STARTING ENGINE. If stator is grounded (defective), and meter test leads contact center DC output pin in white connector (red wire), arcing may occur which may damage wiring.

4. Attach **RED** and **BLACK** test lead probes to AC output terminals in white connector (yellow wires) **1**, Fig. 30. (Meter test clip leads may be attached to either AC output terminal.)
5. With the engine running at 3600 RPM output should be no less than:
26 Volts - 20 Amp System

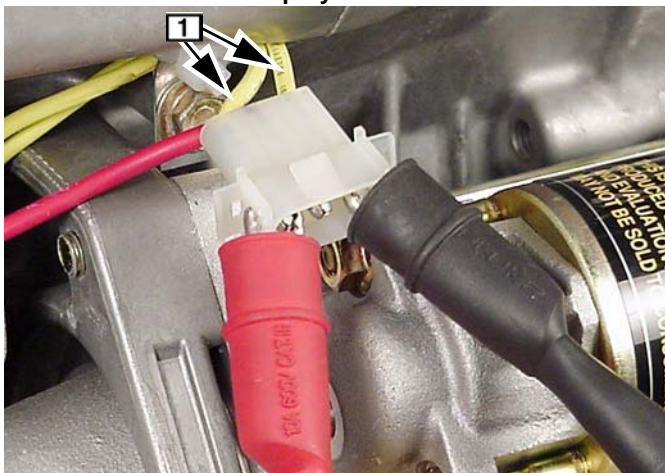

Fig. 30

6. If no or low output is found, check for bare wires or any other obvious defects. If “shorted” leads are not visible, replace the stator.

Testing DC Output Charging Wire

A simple test may be performed to test the DC output charging wire circuit. If a problem exists in the wiring, it can be corrected before testing regulator-rectifier.

Leave stator wire harness disconnected from regulator-rectifier.

Equipment key switch must be in **OFF** position.

1. Insert **RED** test lead into **VΩ** receptacle in meter.
2. Insert **BLACK** test lead into **COM** receptacle in meter.
3. Rotate selector to DC volts position.

4. Attach **RED** test lead probe to DC output terminal **1** in white connector (red wire), Fig.31.



Fig. 31

5. Attach **BLACK** test lead probe to negative battery terminal.
6. Turn equipment key switch to **ON** position. Meter should display battery voltage.
7. If meter does not display battery voltage, check for blown fuse, broken, or shorted wires.

Testing Regulator-Rectifier

Regulator-rectifier will not function unless it is grounded to engine. Make sure the regulator-rectifier is securely mounted to engine.

To avoid blowing fuse in meter when testing DC output of 20 amp system, the DC Shunt, Tool #19468 is required.

The DC Shunt must be installed on the negative (-) terminal of the battery. All connections must be clean and tight for correct amperage readings.

Connect stator wire harness to regulator-rectifier.

1. Install shunt on negative battery terminal.
2. Insert **RED** test lead into **VΩ** receptacle in meter and connect to **RED** post terminal **1** on shunt.
3. Insert **BLACK** test lead into **COM** receptacle in meter and connect to **BLACK** post terminal **2** on shunt, Fig. 32.

4. Rotate selector to 300mV $\overline{\text{---}}$ position.

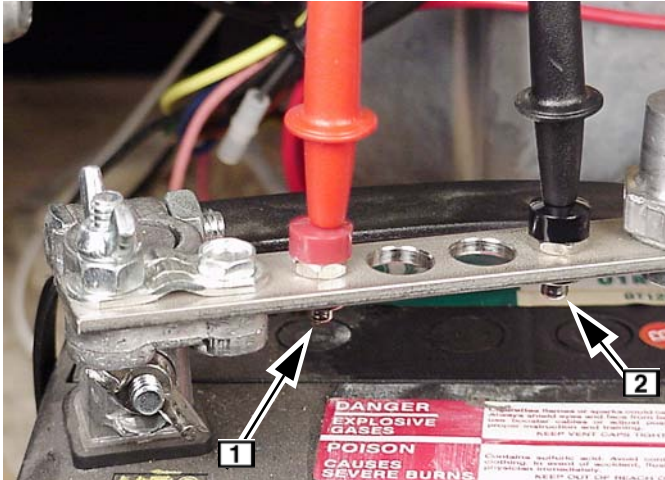

Fig. 32

5. With the engine running at 3600 RPM, the output should be:
- * **3 - 20 Amps - 20 Amp System**
 - * Depending upon battery voltage and/or current draw on system.
6. If no or low output is found, be sure that regulator-rectifier is grounded properly and all equipment connections are clean and secure. If there is still no or low output, replace the regulator-rectifier.

BATTERY INFORMATION

The battery used to operate starter motors on Briggs & Stratton OHV V-Twin engines is a 12-volt, lead acid, wet cell type. This type is available as a wet charge or dry charge battery. The wet charged maintenance-free battery is filled with electrolyte and sealed at the time of manufacture. The level of electrolyte cannot be checked.

The dry charge battery is manufactured with fully charged plates. Electrolyte must be added at the time that the battery is placed in service. Before activating a dry charge battery, read and follow the manufacturer's recommended procedure.

CAUTION: Before servicing battery, disconnect negative (-) battery cable first, then positive (+) cable second.

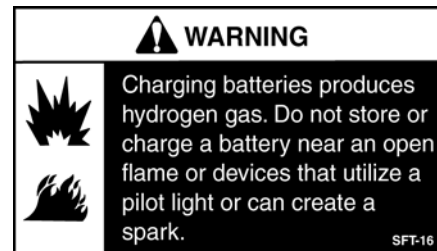

Battery Installation:

1. Before installing battery, connect all equipment to be operated.
2. Place battery in holder with a flat base. Tighten holder down evenly until snug. DO NOT over tighten.
3. Connect positive terminal to positive post FIRST, to prevent sparks from accidental grounding. Tighten connectors securely.
4. Connect negative terminal to negative battery terminal. Tighten connectors securely.

Checking Battery

1. Physical check - clean if necessary.
 - a. Corrosion
 - b. Dirt
 - c. Terminal and clamps (secure - good condition)
2. Bring battery to full charge.



NOTE: Do not exceed charge rate of 1/10 ampere for every ampere of battery rating. Consult battery manufacturer for maximum charge recommendations.

- a. Use a taper charge (automatically reduces charge rate).
- b. Fill battery cells with distilled water or tap water after charging (for batteries that have been in service).
- c. If battery gets "Hot" to the touch or is spitting acid (gassing) excessively, unplug charger periodically.

- With battery fully charged, check specific gravity readings of each cell with a Battery Hydrometer and record readings, Fig. 33. All readings should be above **1.250** (compensating for temperature). If specific gravity readings varied **.50** or if all cells read less than **1.225**, replace battery.

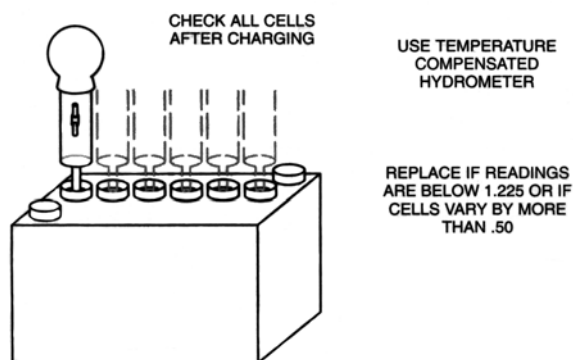

Fig. 33 - Checking 12 V Battery Cells (Lead Acid, Wet Cell, Dry Charge)

Testing Battery

Use Digital Multimeter, **Tool #19464**.

- Set meter to read DC Volts.
- Disconnect wires from spark plugs and ground ignition using two Ignition Testers, **Tool #19368**.

Attach **RED** meter test clip to positive (+) battery terminal. Attach **BLACK** meter test lead to negative (-) battery terminal.

- Turn switch to **START**.

METER SHOULD DISPLAY 9 VOLTS OR MORE WHILE CRANKING ENGINE.

If less than 9 volts, replace battery.

CAUTION: Do not crank starter for more than 15 seconds without allowing starter to cool at least 2 minutes or the starter motor could be damaged.

Battery Recommendations

These battery size recommendations are based on minimum temperature expected and correct weight of oil being used.

- 30 Amp. Hr. +20°F (-6° C) or higher
- 40 Amp. Hr. -5° F (-20° C) or higher

50 Amp. Hr. -15° F (-26° C) or higher

Battery Cable Recommendations

These cable sizes are based on total length of cable from battery positive post to starter switch or solenoid, and to starter plus ground return to battery negative post.

- #6 AWG - 4 ft. (1.2 m) or less
- #5 AWG - 5 ft. (1.5 m) or less
- #4 AWG - 6 ft. (1.8 m) or less

EQUIPMENT AFFECTING ENGINE OPERATION

Frequently, what appears to be a problem with engine operation, such as hard starting, vibration, etc., may be the fault of the equipment powered rather than the engine itself. Since many varied types of equipment are powered by Briggs & Stratton engines, it is not possible to list all of the various conditions that may exist. Listed are the most common effects of equipment problems, and what to look for as the most common cause.

Hard Starting or Will Not Start

- A loose drive belt like a loose blade can cause a backlash effect, which will counteract engine cranking effort.
- Starting under load - see if the unit is disengaged when engine is started; or if engaged, should not have a heavy starting load.
- Check remote control assembly for proper adjustment.
- Check interlock system for shorted wires, loose or corroded connections, or defective modules or switches.

Engine Won't Stop

- Check equipment ignition stop switch.
- Check for loose or disconnected equipment stop switch wire.
- Check engine ground wire harness.

Vibration

- Cutter blade bent or out of balance.
- Mounting bolts loose.



SECTION 3 ENGINE DISASSEMBLY

GENERAL INFORMATION

1. Disconnect battery cables at battery.
2. Disconnect throttle and choke cables.
3. Drain oil and remove oil filter.
4. Drain radiator.

REMOVE MUFFLER

1. Remove muffler bracket screws **1**, and exhaust manifold screws **2**, Fig. 34.

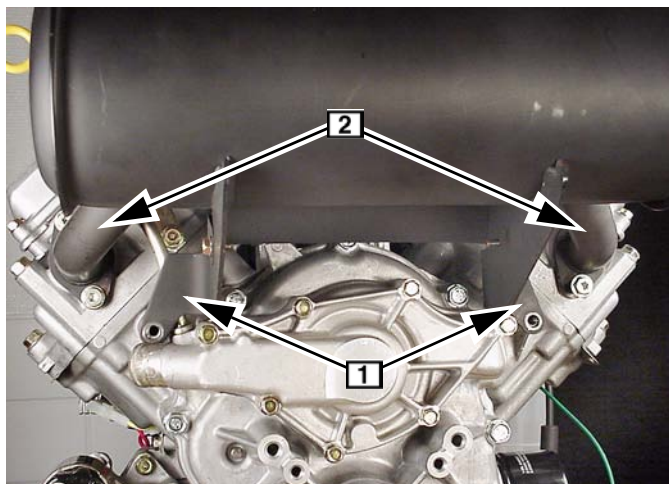

Fig. 34

REMOVE RADIATOR

CAUTION: Radiator fins and tubes are subject to damage from tools or rough handling. Exercise care when servicing.

1. Remove upper **1** and lower **2** radiator hoses, Fig. 35.

2. Disconnect by-pass hose at thermostat housing.

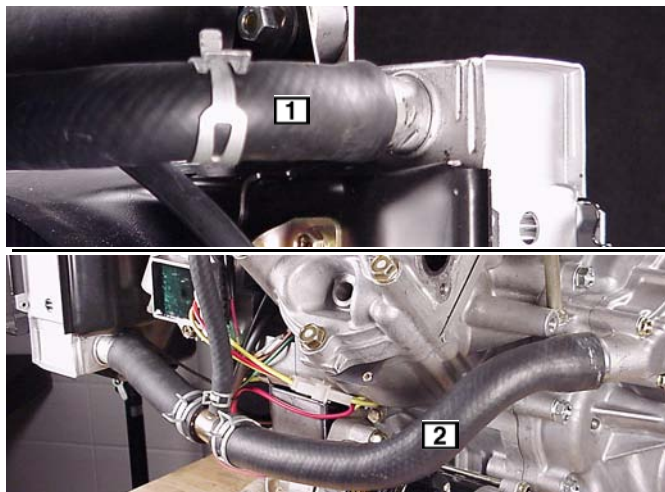

Fig. 35

3. Remove upper and lower radiator mounting nuts and washers.
4. Rotate radiator clockwise so that coolant outlet clears fan shroud, Fig. 36.

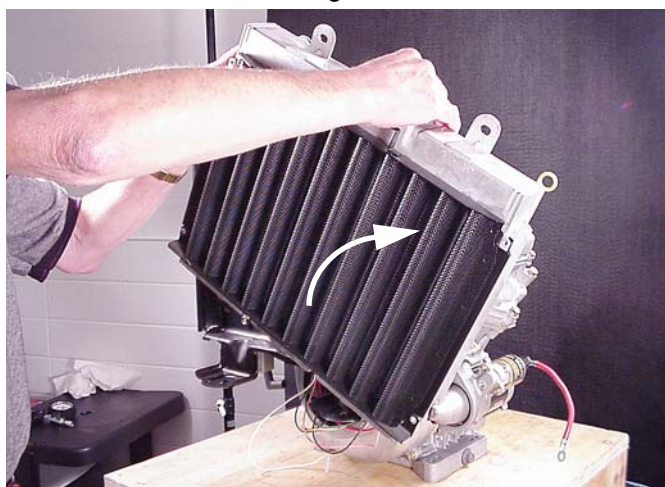

Fig. 36

DISCONNECT FUEL LINES

1. Disconnect fuel line from pump to carburetor **1**, fuel pump pulse line at valve cover **2**, and fuel inlet line at fuel filter **3**, Fig. 37.

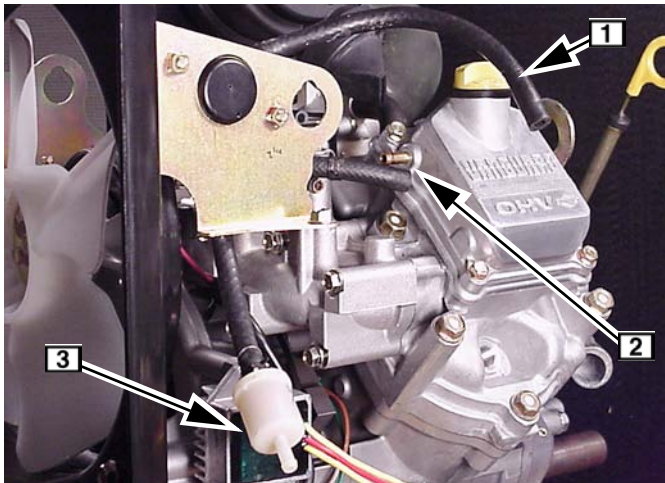

Fig. 37

REMOVE FAN ASSEMBLY

1. Remove lower fan shroud screws **1** and upper fan bracket screws at intake manifold **2**, Fig. 38.
2. Remove fan shroud assembly.

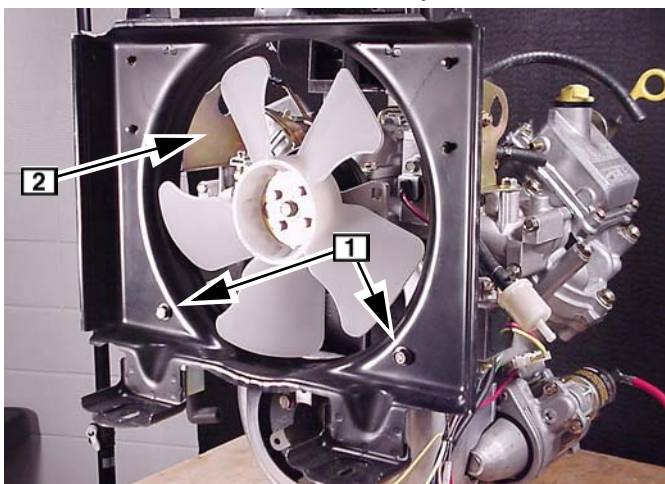

Fig. 38

3. Remove flywheel housing **1**, Fig. 39.



Fig. 39

4. Loosen fan belt and disconnect regulator-rectifier.
5. Remove fan, Fig. 40.

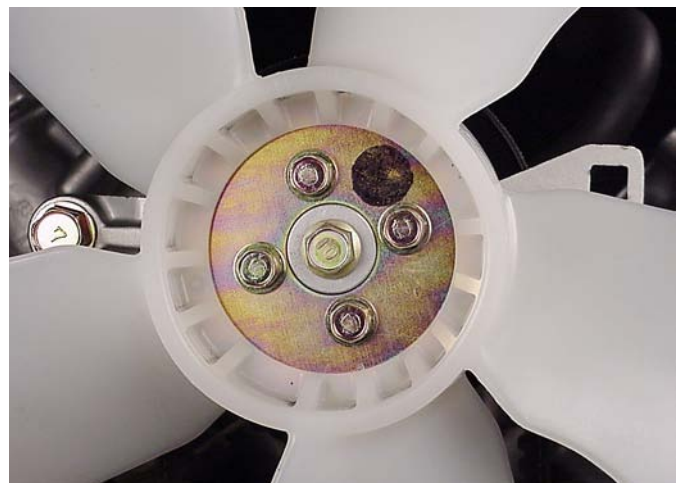

Fig. 40

6. Remove fan adjustment bracket **1**, Fig. 41.

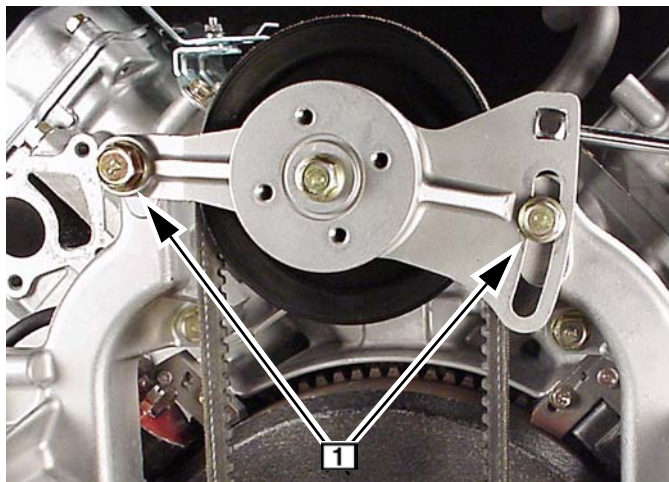

Fig. 41

7. Remove fan brackets **2**, Fig. 42.

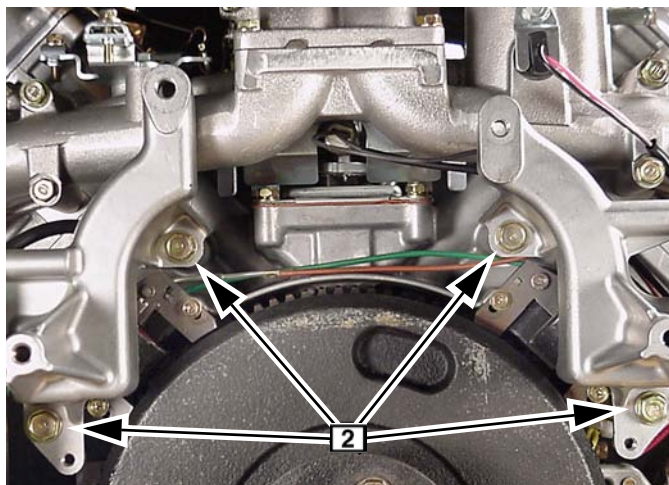

Fig. 42

REMOVE CARBURETOR

1. Remove air cleaner assembly.
2. Disconnect throttle link and spring at carburetor **1**, Fig. 43.

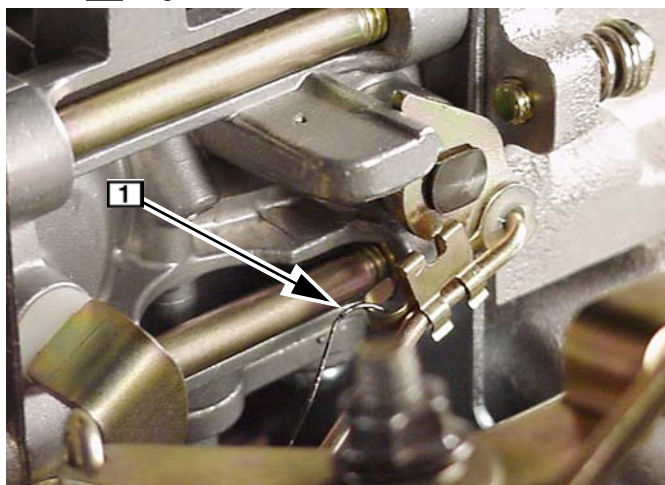

Fig. 43

3. Remove governor lever **1** and disconnect governor springs, Fig. 44.

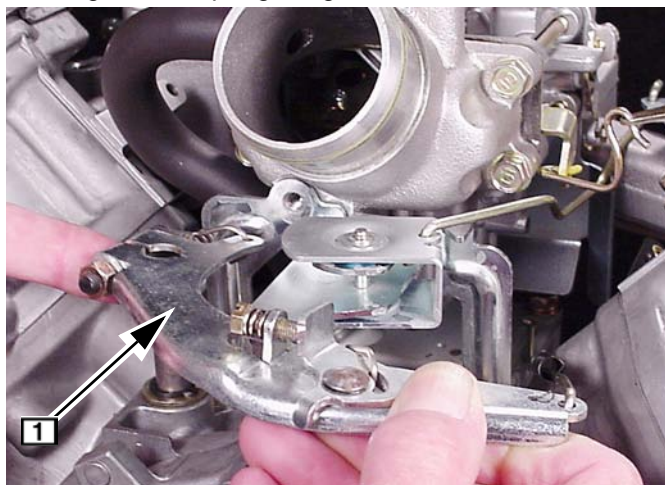

Fig. 44

- Remove governor control bracket **1** and disconnect governor link **2**, Fig. 45.

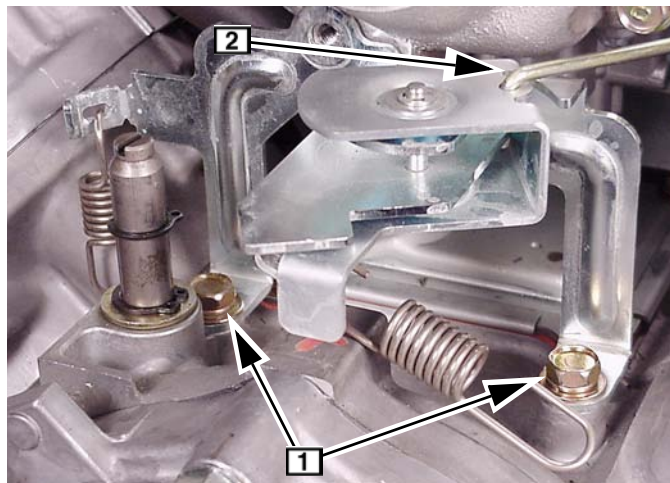

Fig. 45

- Disconnect fuel shut off solenoid wire and remove ground wire.
- Disconnect breather tube at air cleaner elbow **1**, Fig. 46.
- Remove intake elbow screws **2**.
- Remove intake elbow and carburetor assembly.
- Disconnect choke link at choke control.

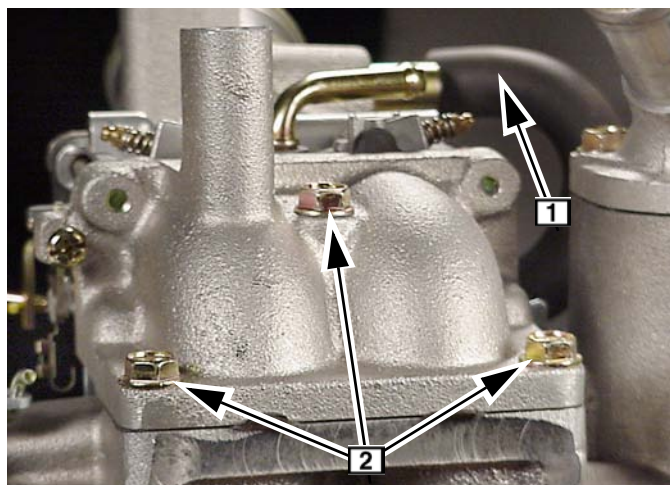

Fig. 46

- Remove air cleaner elbow screws **1**, Fig. 47, and separate carburetor from intake elbow and air cleaner elbow.

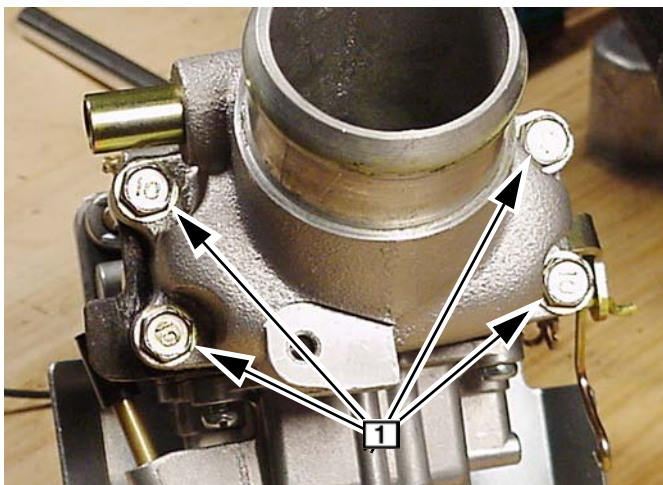

Fig. 47

REMOVE STARTER

- Remove two screws **1** and starter motor, Fig. 48.

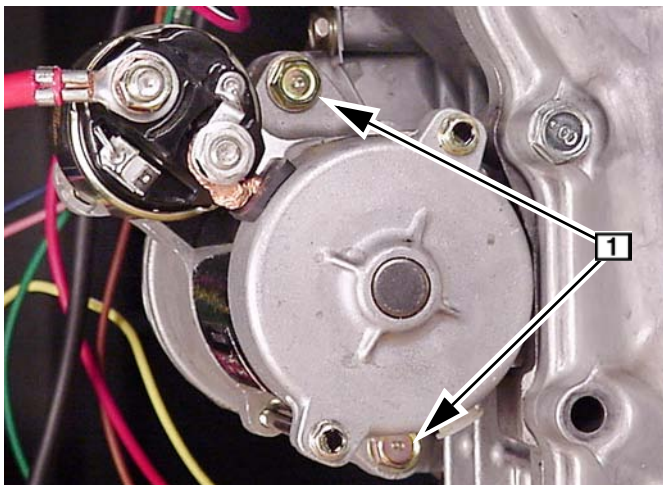

Fig. 48

Remove Flywheel

- Remove armatures **1** and ground wire assembly, Fig. 49.



2. Remove fan belt pulley [2].

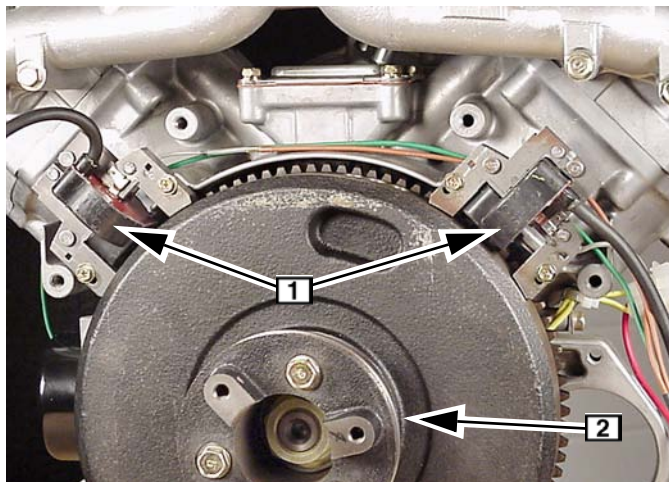

Fig. 49

3. Place flywheel strap wrench, Tool #19433 around flywheel.
4. Loosen flywheel nut, Fig. 50.

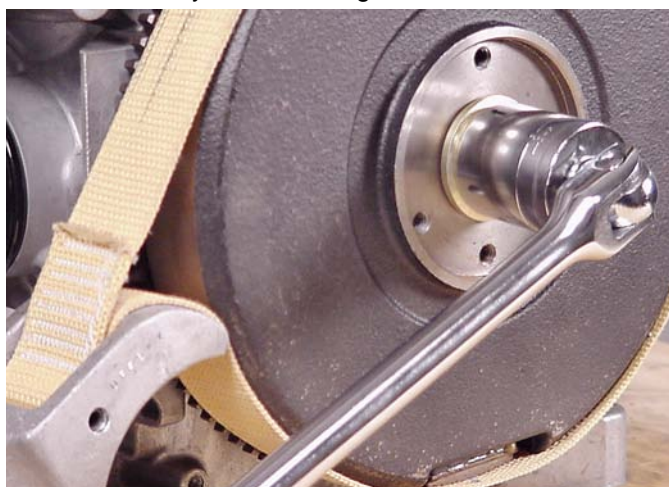

Fig. 50

5. Install flywheel puller, Tool #19203.

6. Tighten puller nuts equally until flywheel loosens, Fig. 51.

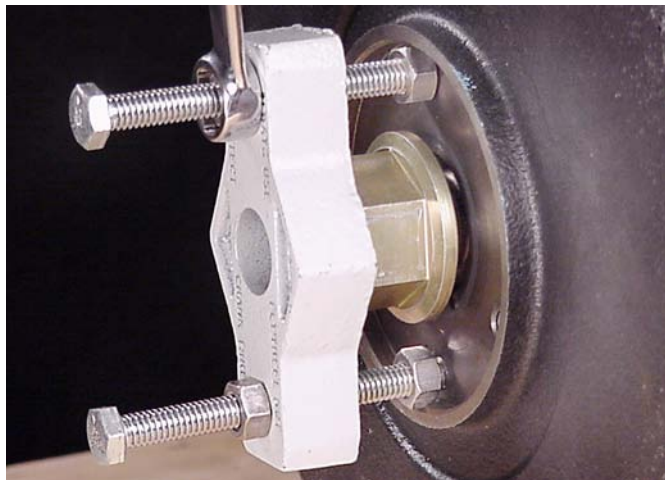



Fig. 51

 **WARNING:** DO NOT strike flywheel with a hard object or a metal tool as this may cause flywheel to shatter in operation. Always use approved removal tools.

REMOVE INTAKE MANIFOLD

1. Remove thermostat cover [1] and thermostat, Fig. 52.
2. Remove intake manifold [2].

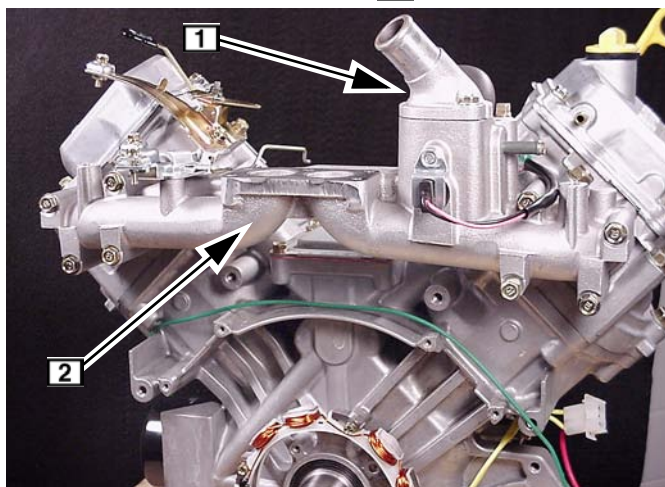

Fig. 52

3. Remove breather, Fig. 53.

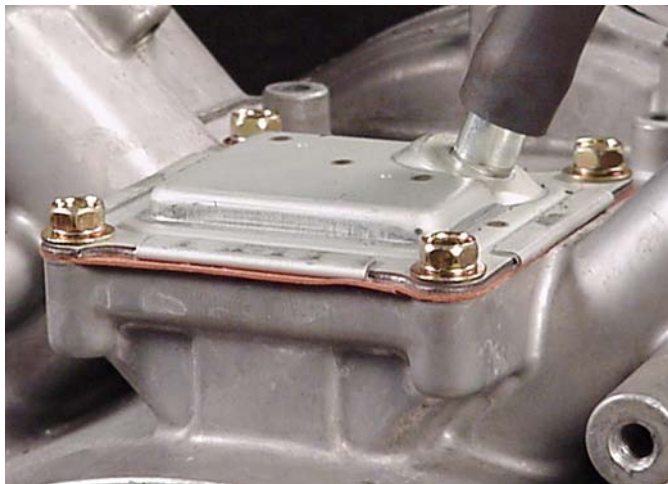

Fig. 53

REMOVE ALTERNATOR

1. Remove alternator harness clamp **1** and alternator **2**, Fig. 54.

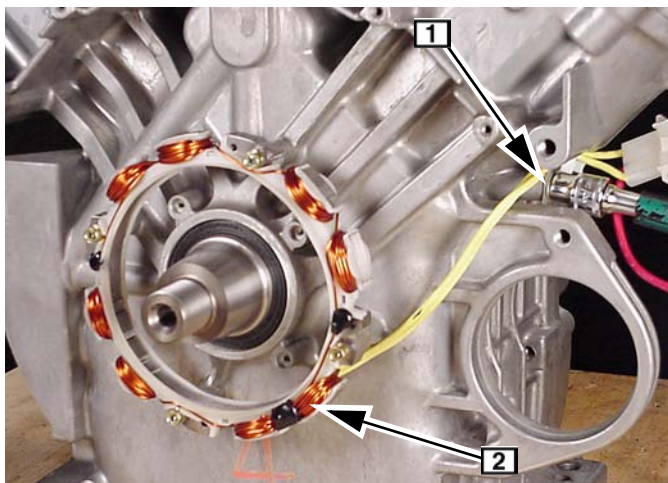

Fig. 54

REMOVE CYLINDER HEADS

1. Remove valve covers.
2. Remove rocker arms **1** and pushrods **2**, Fig. 55.



NOTE: Mark pushrods so that they can be reassembled in their original position.

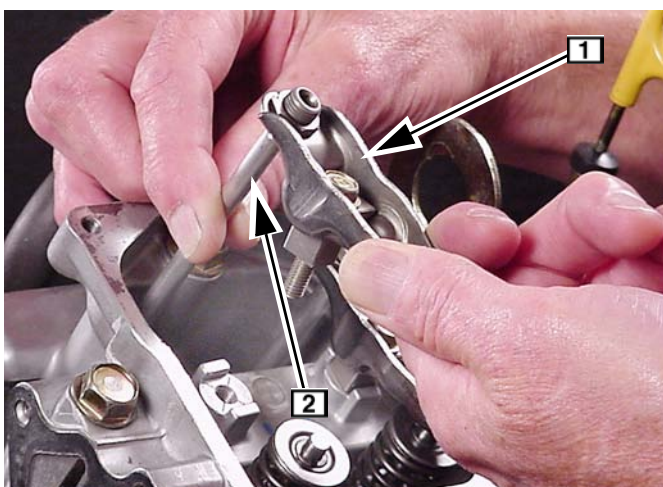

Fig. 55

3. Unscrew 5 head bolts and remove cylinder heads, Fig. 56.

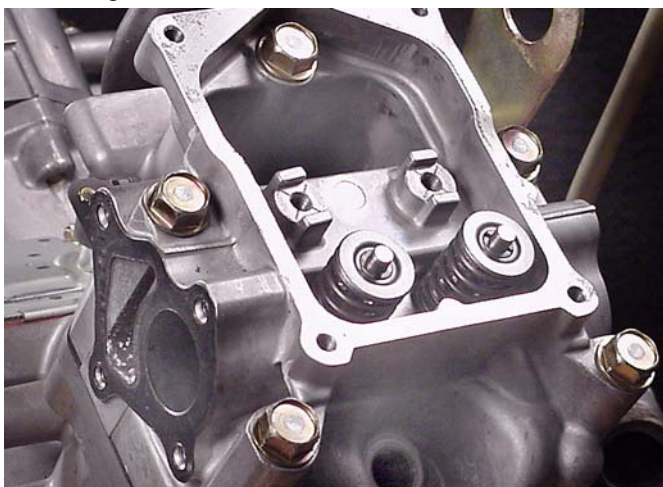

Fig. 56

REMOVE CRANKCASE COVER

1. Remove water pump cover **1**, Fig. 57.
2. Remove water pump impeller **2**.

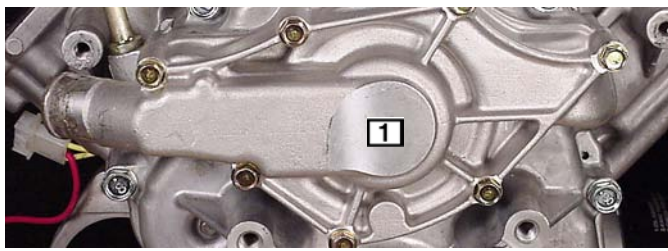

Fig. 57

3. Remove crankcase cover, Fig. 58.

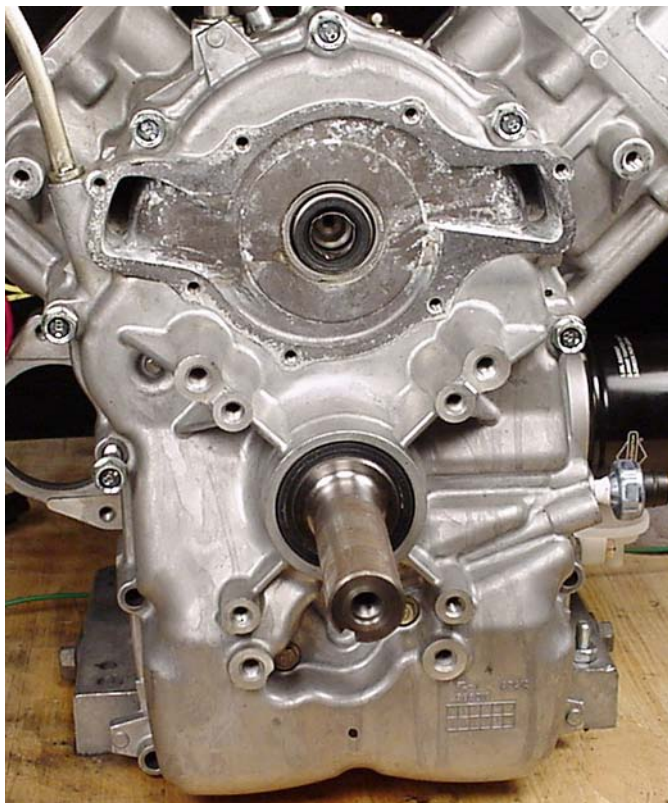

Fig. 58

4. Remove oil pump screws **1** and oil pump **2**, Fig. 59.

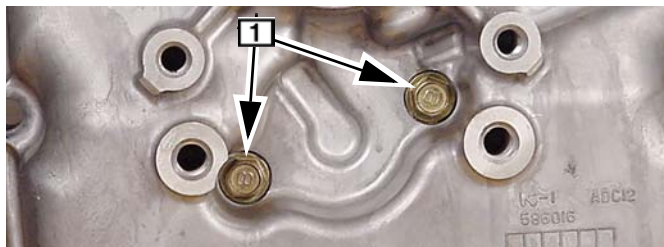

Fig. 59

5. Remove governor gear **1** and thrust washer **2**, Fig. 60.

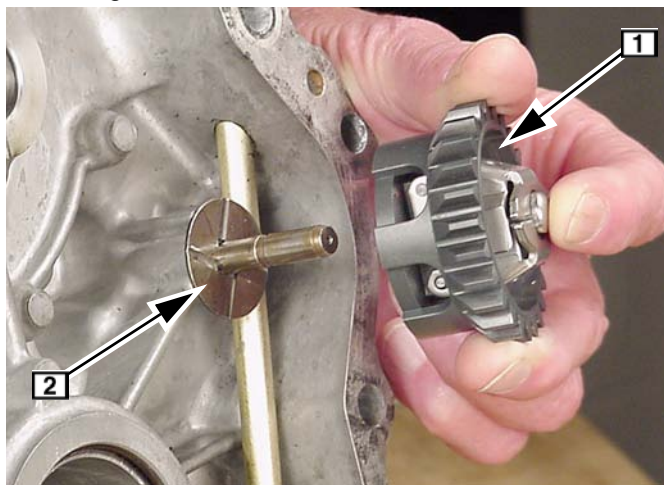

Fig. 60

REMOVE CAMSHAFT

1. Rotate crankshaft and camshaft until timing marks **1** align, then remove camshaft and tappets, Fig. 61.



Fig. 61

REMOVE PISTONS, RODS, CRANKSHAFT



NOTE: Remove any carbon or ridge at the top of cylinder bores to prevent breaking rings when removing piston and connecting rod assemblies.

1. Remove No. 2 connecting rod cap and push connecting rod and piston assembly out of cylinder, Fig. 62.



NOTE: Reassemble cap to rod to prevent interchanging.

2. Repeat for other cylinder.

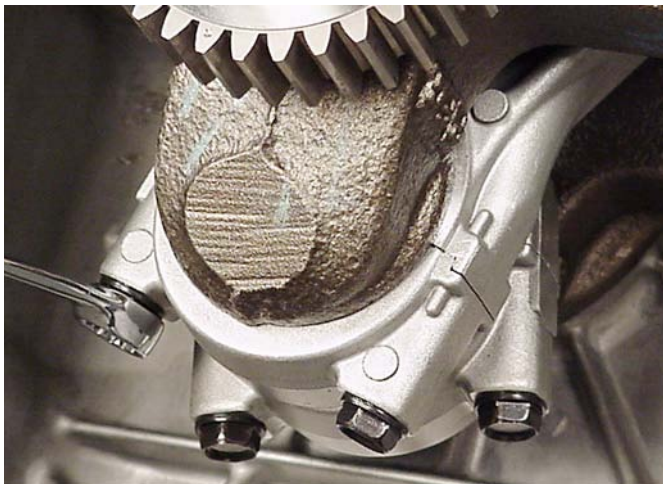

Fig. 62

3. Remove crankshaft.
4. Remove governor shaft, Fig. 63.

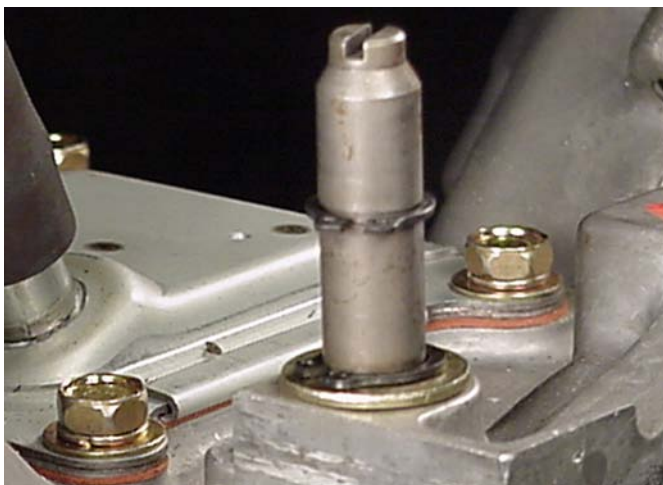

Fig. 63



NOTE: Clean all surfaces of gasket material. Remove oil seals and o-rings. Thoroughly clean components in solvent. Organize components, keeping parts which are an assembly together.



SECTION 4 ENGINE OVERHAUL

CHECK CYLINDER

Check cylinder for cracks or stripped threads. Check cylinder bores for damage or scoring.

1. Check cylinder head mounting surface for distortion with a straight edge, Fig. 64.

If mounting surfaces are distorted more than .004" (0.1 mm), the cylinder must be replaced.

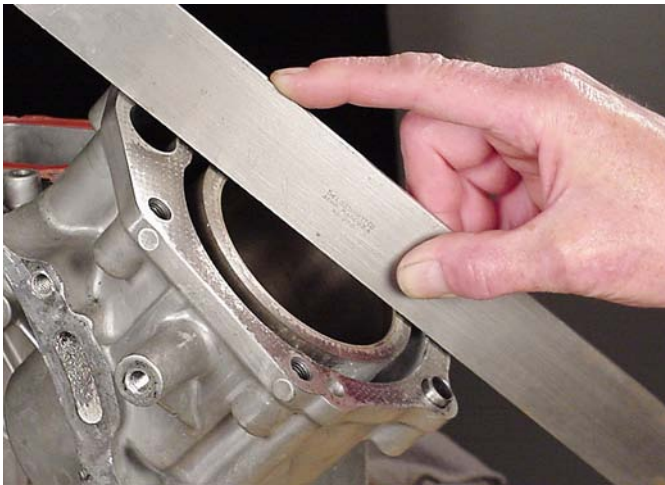

Fig. 64

2. Check cylinder bores for wear using telescoping gauge, Tool #19404 and dial caliper, Tool #19199.

<p>Standard Bore Size: 3.189" - 3.190" (81.00 - 81.02 mm)</p>
--

- a. Measure cylinder bore in 6 points at right angles as shown, Fig. 65.

- b. If cylinder bore is worn more than .003" (0.076 mm) or more than .0015" (0.038 mm) out of round, it must be resized.

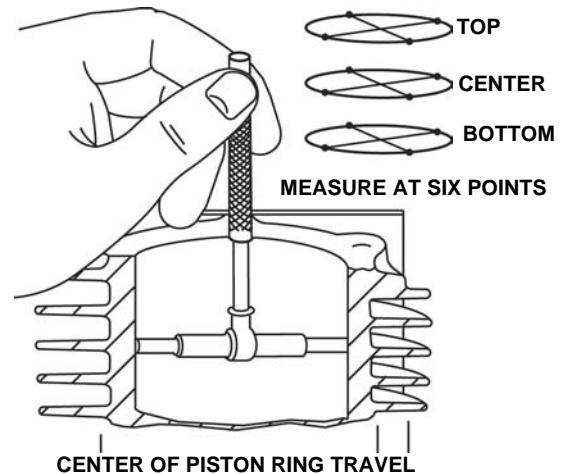

Fig. 65



NOTE: If cylinder bores are within specification and show no signs of scoring or other damage, new piston rings may be installed providing the cylinder bores are reconditioned using a rigid hone with finishing stones, to restore the proper cross hatch angle in the cylinder bores. The proper cylinder crosshatch ensures proper lubrication and piston ring break in. Refer to Page 3, "Cylinder Finish" (Cross Hatch) for correct procedure for installing crosshatch.

Resizing

Always resize to exactly .020" (.51 mm) standard bore size. If this is done accurately, the service oversize rings and pistons will fit perfectly and proper clearances will be maintained.

Cylinders can be quickly resized with a good hone such as Briggs & Stratton Tool #19205. Contact your Briggs & Stratton source of supply. Use the stones and lubrication recommended by the hone manufacturers to produce the correct cylinder cross hatch.



NOTE: Automatic transmission fluid is acceptable honing oil. Another acceptable honing oil can be made by mixing 4 parts No. 30 weight oil with 1 part kerosene.

If a boring bar is used, a hone must be used after the boring operation to produce the proper cylinder cross hatch.

Honing is done with a variable speed 1/2", portable drill and a honing fixture. A suitable honing fixture can be made from a 2" X 8" X 16" block of wood. Use three or four crankcase cover mounting screws and fasten cylinder to the honing fixture.

Clamp honing fixture and cylinder securely in a vise at a convenient work height. Place hone drive shaft in chuck of portable drill and tighten.

Cut a wood block and place inside cylinder to prevent hone from extending further than 3/4" to 1" (19 mm to 25 mm) below cylinder bore.

Place hone in middle of cylinder bore. Tighten adjusting knob with finger until stones fit snugly against cylinder wall. **DO NOT FORCE.** Connect drive shaft to hone. Be sure that cylinder and hone are centered and aligned with drive shaft and drill spindle.

Lubricate hone as recommended by hone manufacturer. The recommended drill speed is 300 to 700 RPM MAXIMUM and 40-60 strokes per minute. Because cylinder bores normally wear only in the area of ring travel, the cylinder bore will be round above and below ring travel, Fig. 66. Start drill and, as hone spins, move it up and down at the bottom of the cylinder bore. Gradually increase the length of the strokes until hone travels full length of cylinder bore, and no more than 3/4" to 1" above cylinder bore, Fig. 66. Lubricate hone frequently to prevent build up on stones.

As cutting tension decreases, stop hone and tighten adjusting knob following hone manufacturer's recommendations. Check cylinder bore frequently.

Lubricate hone as recommended by hone manufacturer. The recommended drill speed is 300 to 700 RPM MAXIMUM and 40-60 strokes per minute. Because cylinder bores normally wear only in the area of ring travel, the cylinder bore will be round above and below ring travel, Fig. 66. Start drill and, as hone spins, move it up and down at the bottom of the cylinder bore. Gradually increase the length of the strokes until hone travels full length of cylinder bore, and no more than 3/4" to 1" above cylinder bore, Fig. 66. Lubricate hone frequently to prevent build up on stones.

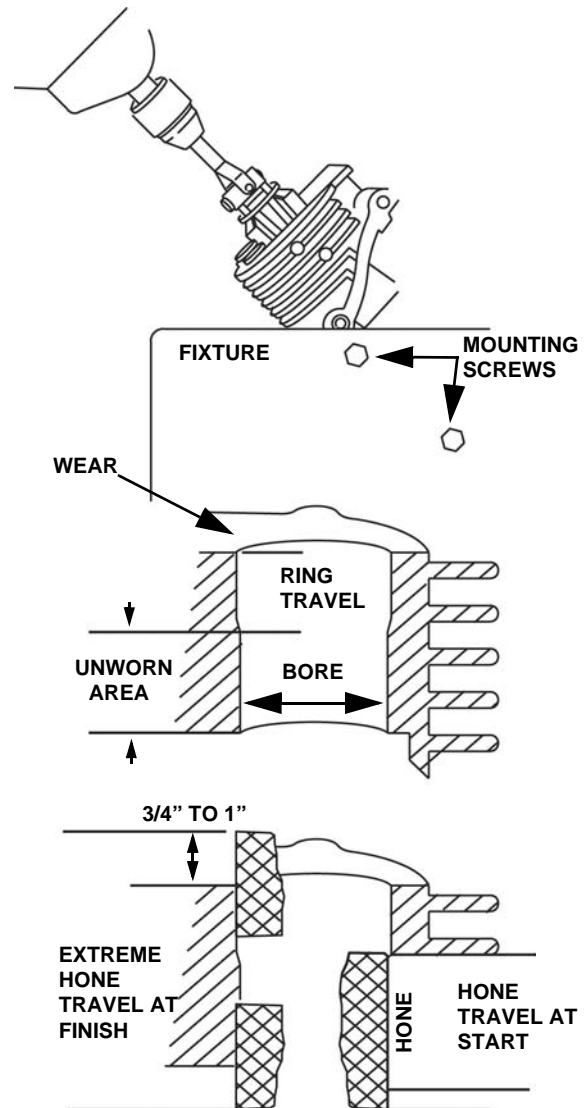

Fig. 66

As cutting tension decreases, stop hone and tighten adjusting knob following hone manufacturer's recommendations. Check cylinder bore frequently.

Cylinder Finish (Cross Hatch)

The finishing stones are used after the cylinder bore has been resized to within .0015" (.04 mm) of the desired size or when reconditioning a cylinder bore. The finishing stones will produce the correct cross hatch necessary for proper lubrication. The correct cross hatch angle is approximately 45 degrees, Fig. 67.

It is recommended that the cylinder bores be reconditioned to restore the cross hatch when new piston rings are to be installed in a cylinder that is within

specification. Be careful not to hone oversize or it will be necessary to resize the cylinder.



NOTE: To produce the proper cross hatch finish use a drill speed of approximately 200 RPM and 40-60 strokes per minute. Lubricate hone liberally to prevent build up on finishing stones.

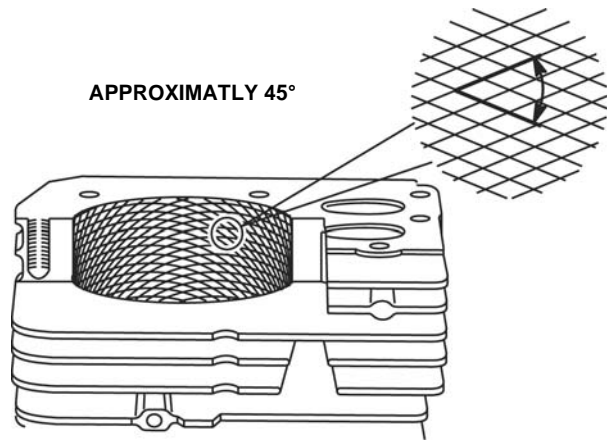

Fig. 67

Cleaning

IT IS MOST IMPORTANT THAT THE ENTIRE CYLINDER AND CRANKCASE BE THOROUGHLY CLEANED AFTER HONING. First, wash the cylinder and crankcase carefully in a solvent such as kerosene or commercial solvent. Then thoroughly wash cylinder and crankcase using a stiff brush with soap and hot water. Rinse thoroughly with hot running water. Repeat washing and rinsing until all traces of honing grit are gone.

Honing grit is highly abrasive and will cause rapid wear to all of the internal components of the engine unless it is completely removed.



NOTE: When cylinder and crankcase have been thoroughly cleaned, use a clean white rag or napkin and wipe the cylinder bore. If honing grit is present, it will appear as a gray residue on rag. If any honing grit is evident, re-wash and rinse entire cylinder and crankcase and check again. When there is no trace of honing grit on rag, the cylinder is properly cleaned. Then oil cylinder bore to prevent rusting.

BEARINGS

Check Mag Bearing

Check magneto bearing for wear or damage, Fig. 68.

Reject Dimension: 1.7765" - (45.12 mm)

If bearing is worn or damaged, the cylinder must be replaced.



Fig. 68

Check Camshaft Bearings

Check camshaft bearings in cylinder and crankcase cover for wear or damage, Fig. 69.

Reject Dimension: .790" (20.06 mm)

If bearings are worn or damaged, the cylinder or crankcase cover must be replaced.

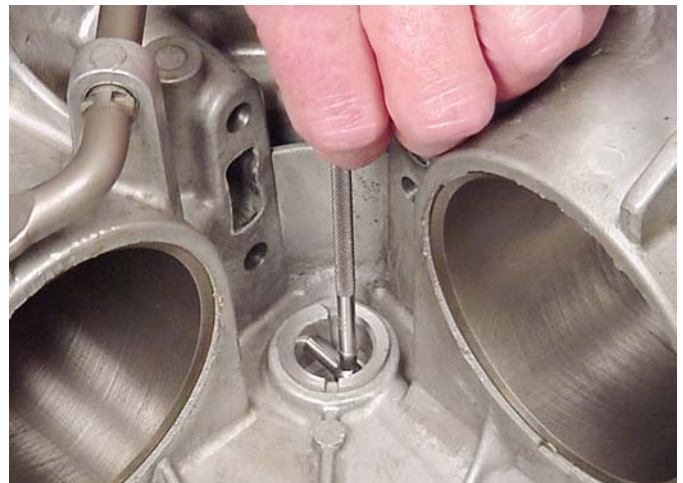

Fig. 69

Check PTO Bearing

Check PTO bearing for wear or damage, Fig. 70.

Reject Dimension: 1.7765" (45.12 mm)

If PTO bearing is worn or damaged, the crankcase cover must be replaced.



Fig. 70

CRANKSHAFT

Check Crankshaft

Inspect crankshaft threads and keyways for damage or wear. If threads or keyways are damaged or worn, replace crankshaft. Check journals for scoring and wear, Fig. 71.

If journals are scored or worn, replace crankshaft.

Crankshaft Reject Sizes:
PTO Journal: 1.7695" (44.94 mm)
Mag Journal: 1.7695" (44.94 mm)
Crankpin Journal: 1.6525" (41.97 mm)



Fig. 71

Check Camshaft

Inspect gear teeth, lobes and journals for wear and nicks. Camshaft journal and lobe reject sizes are shown below. Replace cam gear if not to specification.

Camshaft Reject Sizes:
Journals: (Mag & PTO) .7845" (19.93 mm)
Lobes: (Int. & Ex.) 1.342" (34.08 mm)

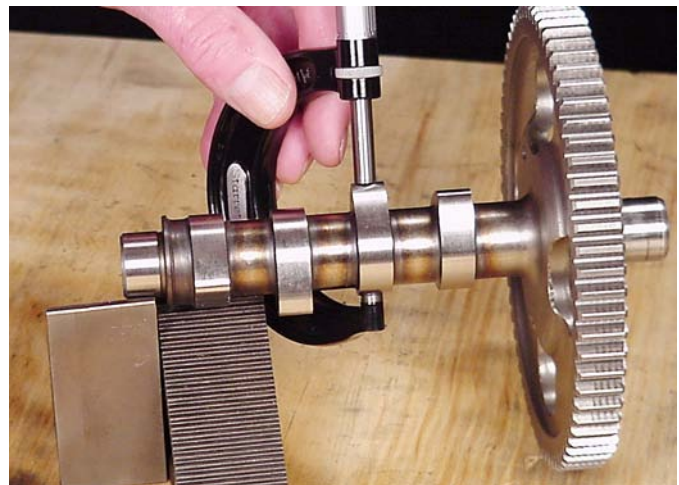

Fig. 72

PISTON, RINGS AND CONNECTING ROD DISASSEMBLY AND INSPECTION

Measure cylinder bores before checking pistons and rings. If cylinder bore(s) require re-sizing it will not be

necessary to check pistons and rings since a new oversized piston assembly will be used.

Disassemble Piston and Connecting Rod

1. Remove piston top and center rings using ring expander, Tool #19340, Fig. 73.
 - a. Remove top oil scraper ring, then bottom scraper ring.
 - b. Remove expander.

TOOL #19340

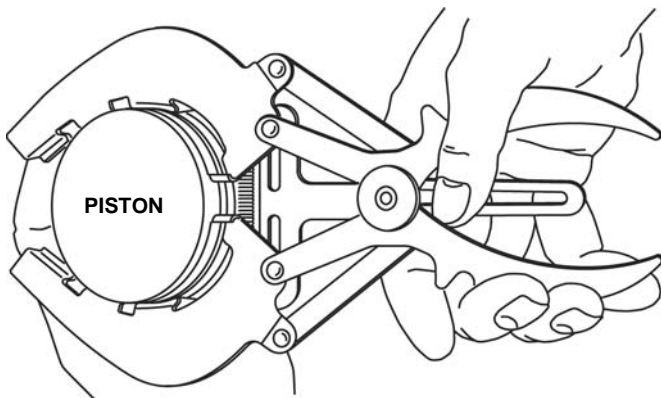

Fig. 73

2. Disassemble piston from connecting rod, Fig. 74.
 - a. Remove piston pin locks.
 - b. Piston pin is a slip fit in piston and connecting rod.

Keep pistons and connecting rods together as an assembly. Do not mix.

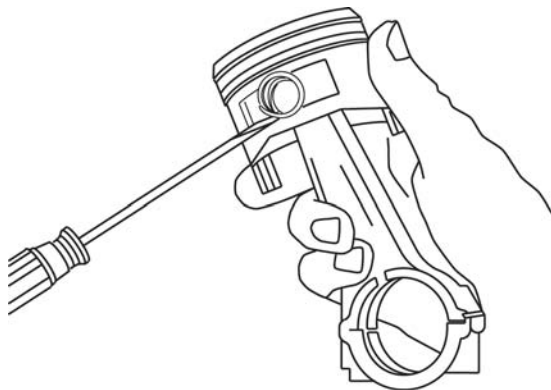

Fig. 74

Check Piston And Rings

If the cylinder is not going to be resized and the piston shows no signs of scoring, the piston should be checked.

1. Check side clearance of ring grooves using NEW rings, Fig. 75.

Compression Rings:

- a. If a **.005" (0.12 mm)** feeler gauge can be inserted, the ring groove is worn. The piston must be replaced.

Oil Rings:

- b. If a **.007" (0.18 mm)** feeler gauge can be inserted, the ring groove is worn. The piston must be replaced.

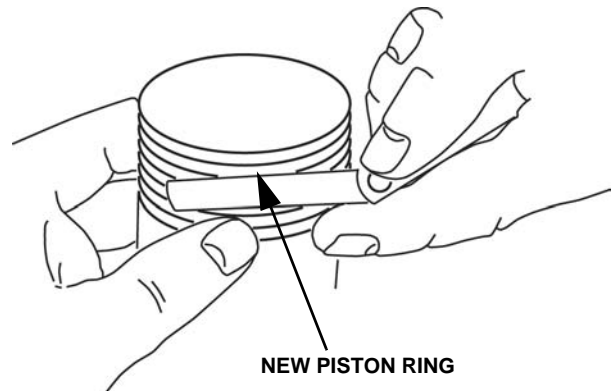

Fig. 75

2. Check ring end gap, Fig. 76.

- a. Clean carbon from end of rings and insert approximately 1" (25 mm) into cylinder.

Reject Dimension (all): .030" (0.76 mm)

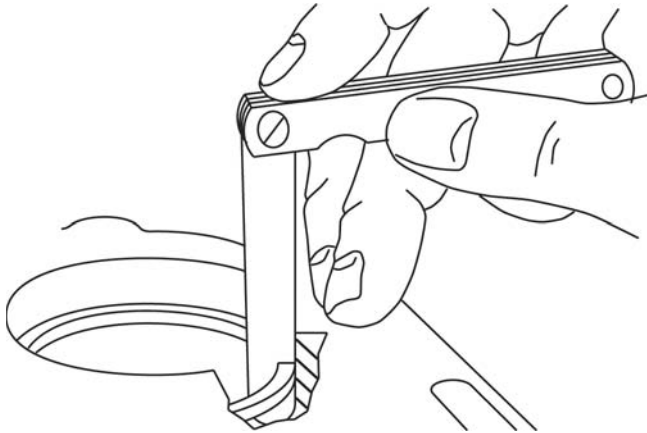

Fig. 76

3. Check piston pin bore, Fig. 77.

Replace if greater than .828" (21.03 mm).

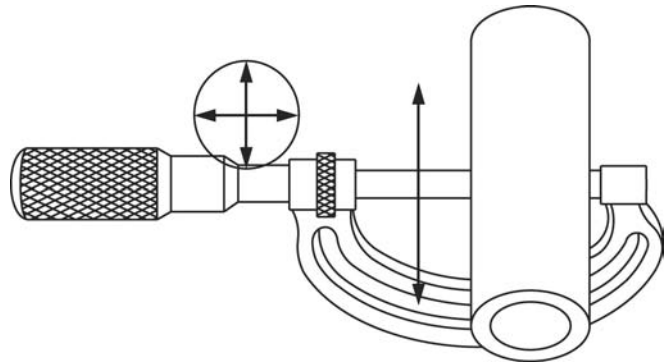

Fig. 78

2. Check connecting rod bearings, Fig. 79.



NOTE: If crankpin bearing is scored or worn the connecting rod must be replaced.

Connecting Rod Reject Sizes:
Crankpin Bearing 1.658" (42.11 mm)
Piston Pin Bearing .8285" (21.04 mm)

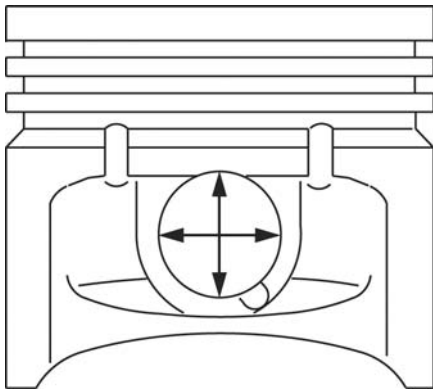

Fig. 77

Check Piston Pin And Connecting Rod

1. Check piston pin, Fig. 78.

Replace if less than .826" (20.98 mm).

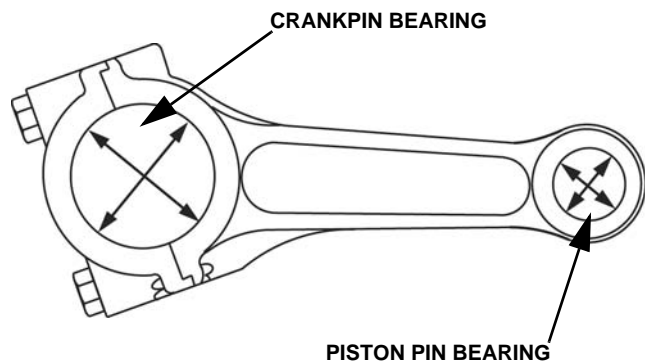

Fig. 79

CYLINDER HEAD INSPECTION AND REPAIR

Disassemble Cylinder Head

1. Place a shop rag or short section of rubber fuel line under valves inside combustion chamber to hold valve in place while compressing spring.
2. Thread rocker arm support screw into cylinder head a few turns and compress spring with valve spring compressor, Tool #19347, Fig. 80. Remove the following:
 - a. Valve spring retainer locks
 - b. Valve spring retainers
 - c. Valve springs
 - d. IN and EX valves

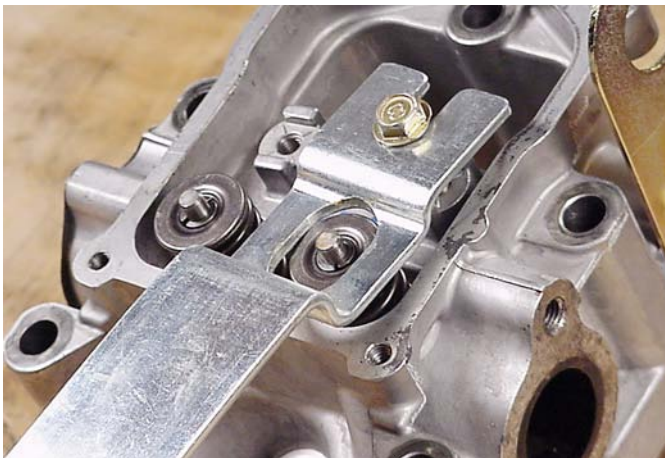

Fig. 80

3. Remove and discard valve stem seals, Fig. 81.

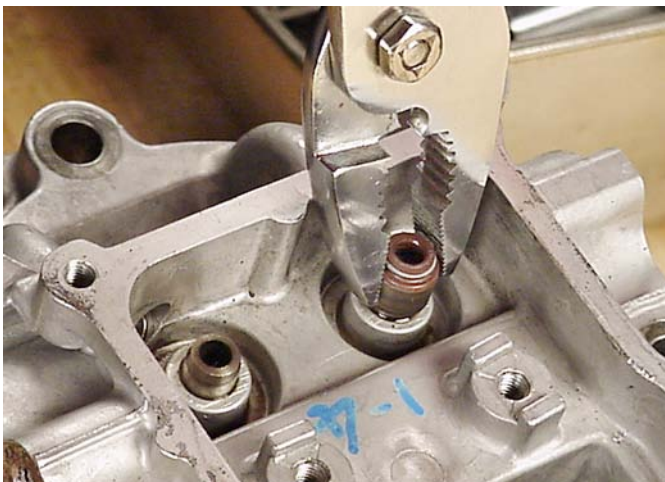

Fig. 81

Inspect And Repair

1. Check cylinder head. Be sure all gasket material is removed from surfaces before checking. Use a gasket scraper if necessary.
 - a. Inspect cylinder head for cracks or damage.
 - b. Use a surface plate or straight edge and check cylinder head mounting surface for distortion.

If mounting surfaces are distorted more than .004" (0.1 mm), the cylinder head must be replaced, Fig. 82.

It is not recommended that cylinder head mounting surfaces be resurfaced.

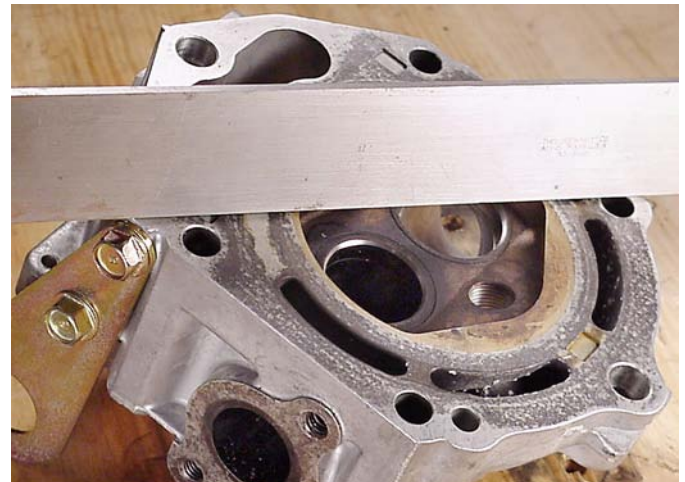

Fig. 82

2. Check valve guide bushings for wear using reject gauge, Tool #19382 **1**, Fig. 83.
 - a. Replace valve guide if gauge enters guide 1/4" (6 mm) or more.

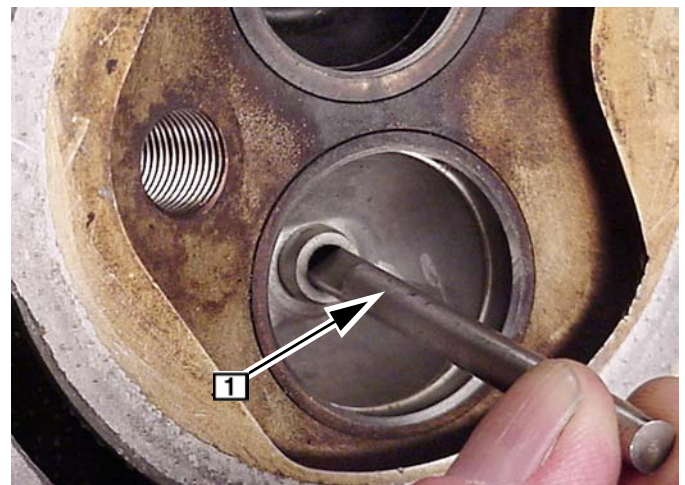

Fig. 83

Remove Valve Guide

1. Press out old valve guide using bushing driver, Tool #19367 **1**, Fig. 84.

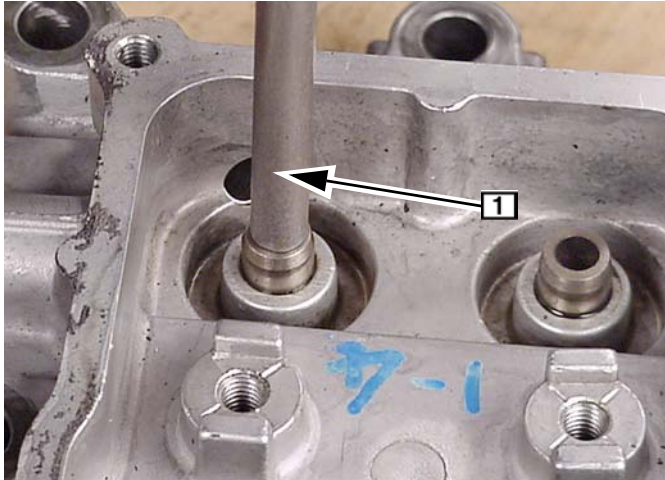

Fig. 84

Install Valve Guide

1. Press in new valve guide using bushing driver, Tool #19416 **1**, Fig. 85.
 - a. Press in until tool bottoms on valve guide bushing boss.

CAUTION: Do Not use a hammer to install bushing.

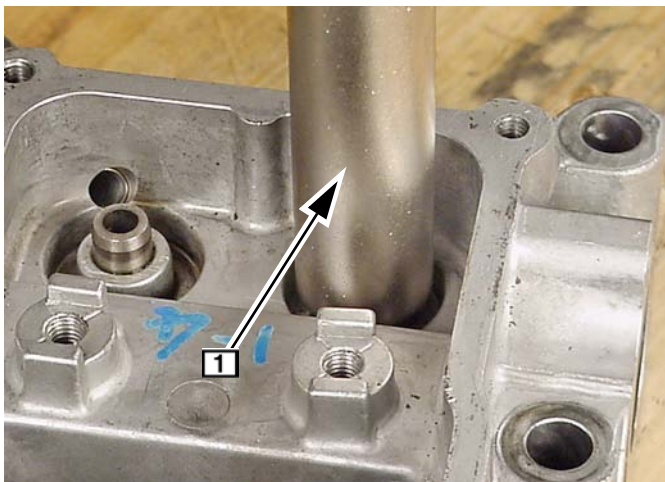

Fig. 85

2. Use reamer pilot guide, Tool #19345 **1** and finish reamer, Tool #19444 **2** and ream new valve guide, Fig. 86.
 - a. Use Stanisol or kerosene to lubricate reamer.

- b. Turn reamer clockwise through entire guide.
- c. Keep turning reamer clockwise when removing reamer.
- d. Flush out all chips.

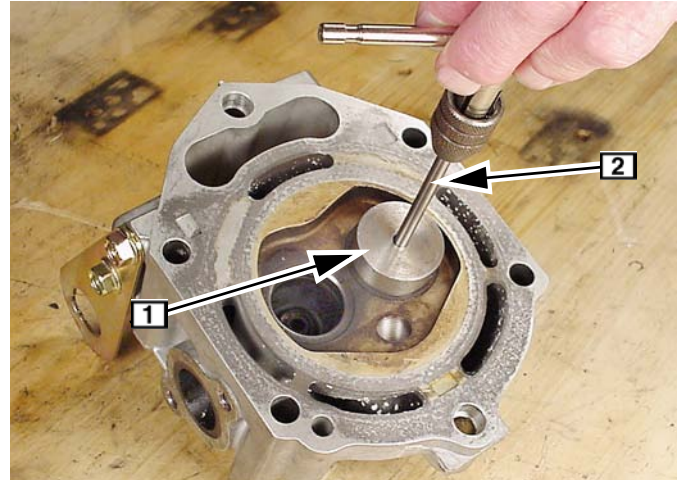

Fig. 86

Reface Valves And Seats

1. Measure valve stem diameter at specified distance from end of valve, as shown in Fig. 87.

Replace if less than .233" (5.92 mm).

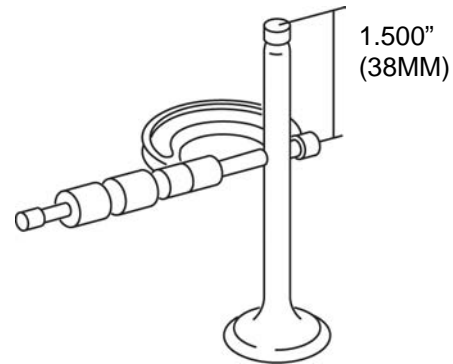

Fig. 87

2. Valve seats may be reconditioned using valve seat cutter tool #19237 and #19343. If valve seat is wider than dimension shown in Fig. 88, a narrowing cutter should be used to ensure that contact area of valve seat is centered on face of valve as shown in Fig. 89.

- a. Use a 605 cutter to narrow seat from bottom and a 155 cutter to narrow seat from top, Fig. 88.



NOTE: If valve seat is loose or cracked, replace cylinder head.

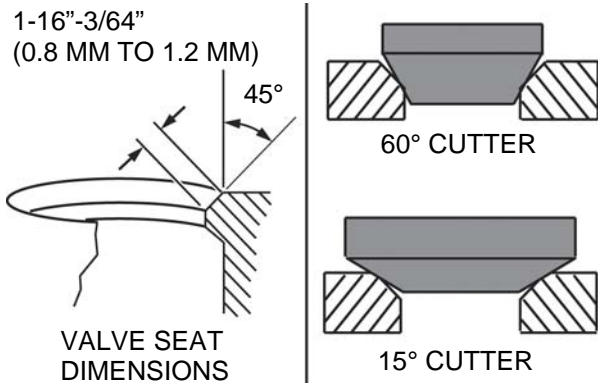

Fig. 88

3. Valve faces may be resurfaced to 45°. See Fig. 89 for dimensions for valves.

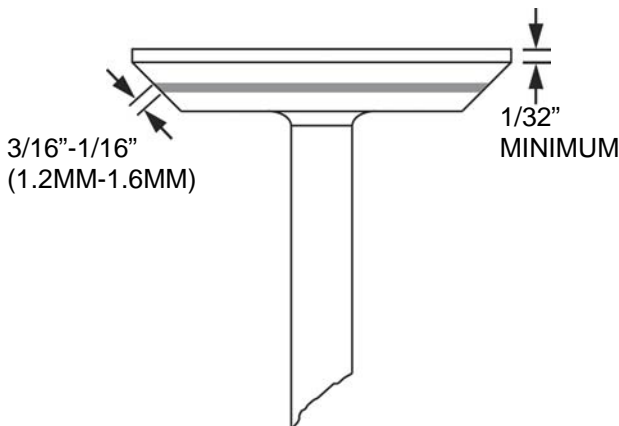

Fig. 89

4. Lap valves and seats with valve lapping tool, #19258 and valve lapping compound, tool #94150.



NOTE: In most instances it is more economical to replace the valves than to reface them.

Assemble Cylinder Head

1. Use valve guide driver, Tool #19416 **1** and install new intake valve stem seals, Fig. 90.
 - a. Oil inner surface and lip of valve stem seal.
 - b. Press seal on to valve guide bushing until it bottoms.

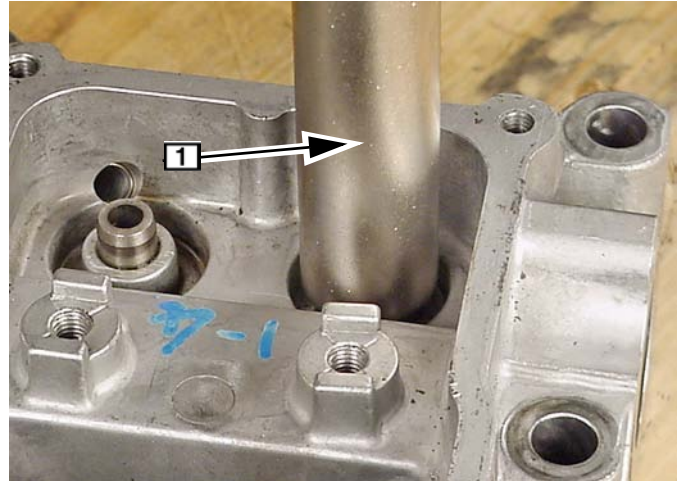

Fig. 90

2. Install valves, Fig. 91.



NOTE: Lightly coat valve stems with Valve Guide Lubricant #93963 before installing valves but be sure valve guide lubricant is **NOT** on valve face, seat or end of valve stem.

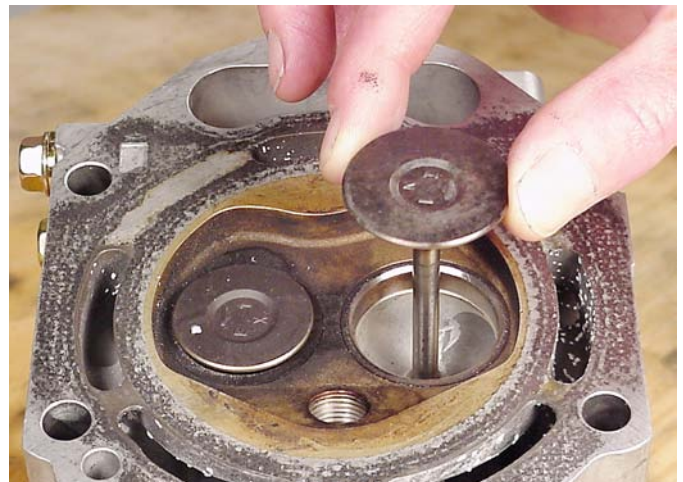

Fig. 91

3. Place a shop rag or short section of rubber fuel line under valves inside combustion chamber to hold valve in place while compressing spring.
4. Install springs and valve spring retainers over valve stems.
5. Temporarily, install rocker arm support screws in cylinder head.
6. Compress valve spring with Tool #19347 and install split retainers, Fig. 92.

Repeat procedure for other valves. Remove rocker arm screws.

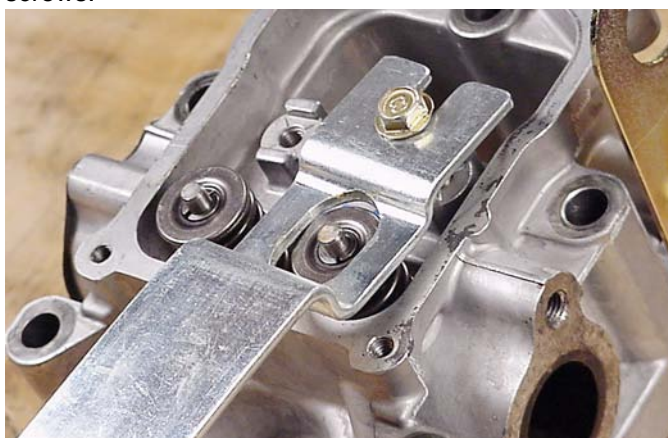

Fig. 92

OIL PUMP

Disassemble Oil Pump

1. Remove two screws and oil pump gear baffle **1**, Fig. 93.

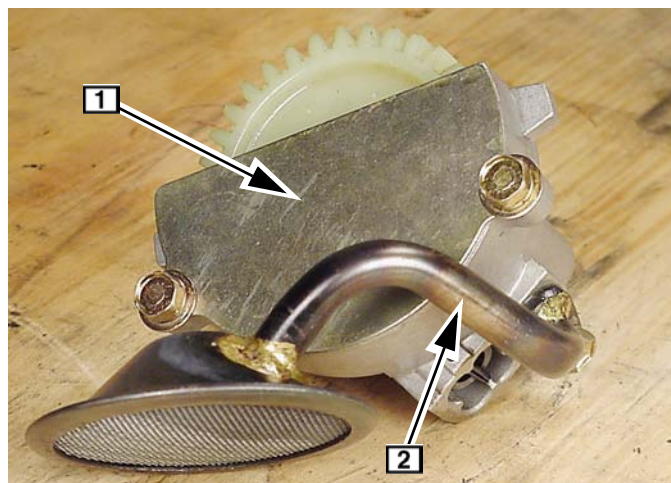

Fig. 93

2. Remove oil pick-up tube and screen assembly **2**.
 - a. Discard O-ring.

Inspect Oil Pump

Inspect pump drive gear for obvious wear or chipped teeth. Inspect pump rotors, housing and crankcase cover or sump for scoring or wear. Replace as required.

Assemble Oil Pump

Lubricate outer rotor with oil and install in pump, Fig. 94.

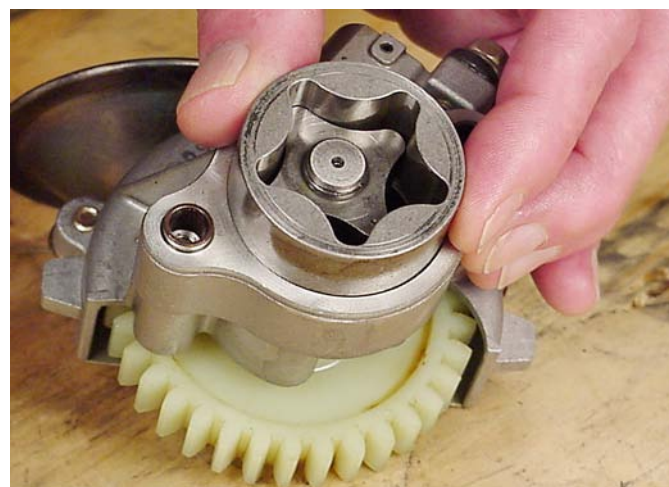

Fig. 94

1. Assemble oil pick-up tube and screen assembly with new O-ring to pump.
 - a. Torque screw to 70 in. lbs. (8.0 Nm).
2. Install oil pump gear baffle, Fig. 95.
 - a. Torque screw to 70 in. lbs. (8.0 Nm).
3. Assemble oil pump to crankcase cover with new O-rings, Fig. 95.

a. Torque screw to 70 in. lbs. (8.0 Nm).

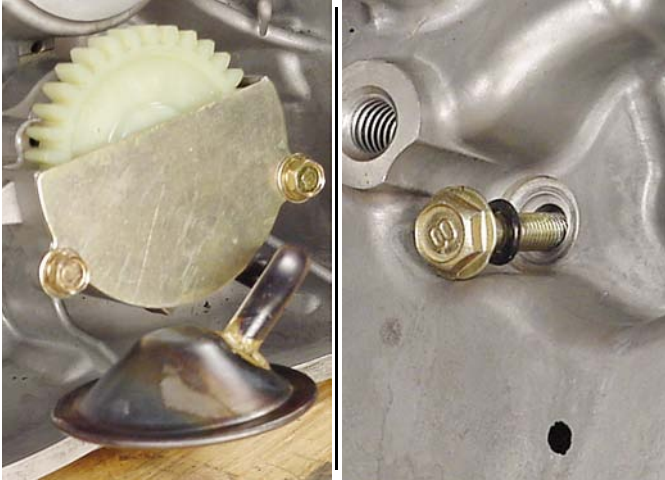

Fig. 95

Check Breather

The engine utilizes a breather valve to control and maintain a vacuum in the crankcase. The breather vents crankcase vapors through the air cleaner.

The reed valve is spring-loaded and must make a complete seal around the vent holes **1** in breather body, Fig. 96. Check to see that reed valve is not deformed. **DO NOT USE FORCE ON REED VALVE.**

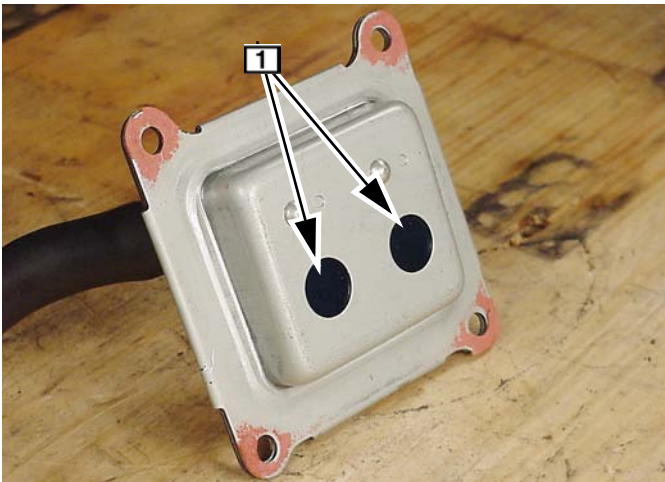

Fig. 96

REPLACING WATER PUMP SEAL

The water pump seal may be replaced without removing the crankcase cover from the engine. The water pump housing and water pump impeller must be removed. If any evidence of coolant is observed in the oil, this indicates that the oil seal behind the water pump seal is leaking. To replace the oil seal, the crankcase cover must be removed.

To remove the oil seal, use the same tools and procedure for removing the water pump seal.

The following tools are required to remove the water pump seal, Fig. 97:

- Puller Nut #19140 **1**
- Puller Stud #19398 **2**
- Support Driver #19394 **3**
- Pilot Nut #19395 **4**
- 1/2" Flat Washer **5**
- Nut #94814 **6**



Fig. 97

Removing Water Pump Seal

1. Assemble puller nut **1** to puller stud **2** with chamfered side down as shown in Fig. 97.
2. Insert nut and stud through water pump seal at a slight angle as far as it will go, Fig. 98.

- Then, carefully drive stud and puller nut the rest of the way through seal.

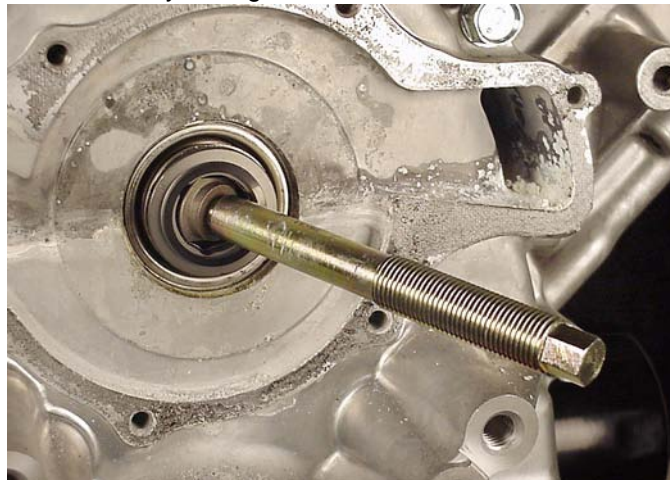

Fig. 98

- Center the puller and stud in water pump seal and then rotate puller and stud 90°.
- Assemble support driver [3], pilot nut [4], washer [5], and nut [6] to puller stud and center assembly over water pump seal.
- Hold hex head of puller stud and tighten nut until water pump seal is removed.
- Thoroughly clean seal bearing surfaces.

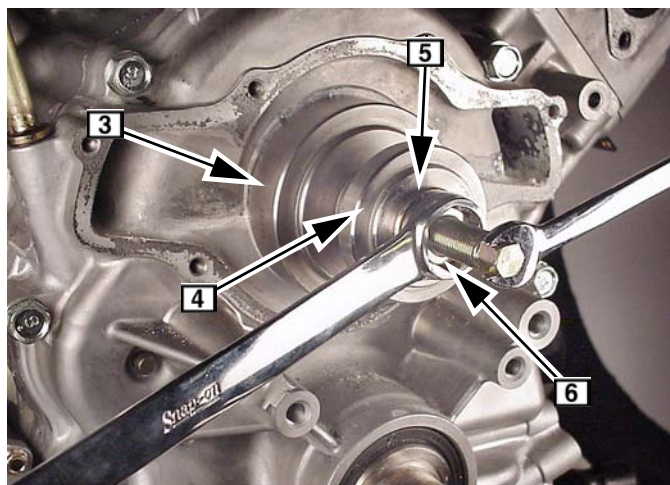

Fig. 99

Installing Water Pump Seal

- Press or drive in new water pump seal until it bottoms with a 32 mm 12 point socket, Fig 100.



Fig. 100

REPLACING STARTER SOLENOID

- Remove nut and field coil wire from stud terminal.
- Remove solenoid mounting nuts and solenoid.
- Lift solenoid to disengage drive lever from plunger, Fig. 101.



NOTE: Hold starter in vertical position with drive housing side down when removing and installing solenoid.



Fig. 101

4. Engage flats on plunger **1** with fork in drive lever **2** and assemble solenoid to starter, Fig. 102.
 - a. Torque nuts to 70 in. lbs. (8.0 Nm).
5. Install field coil wire and nut.
 - a. Torque nut to 90 in. lbs. (10.0 Nm).

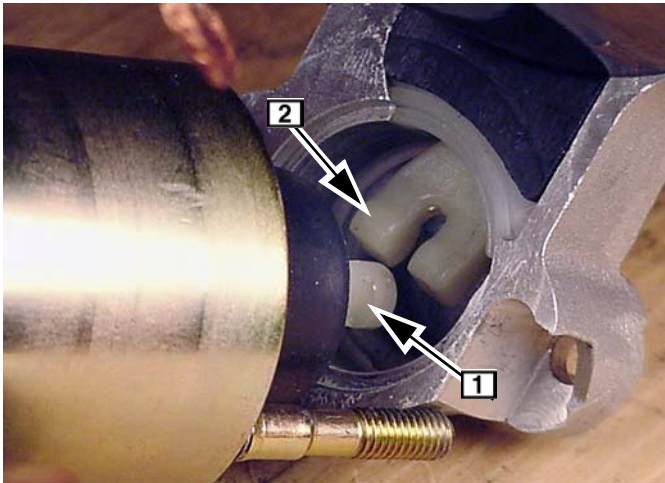

Fig. 102

REPLACING PINION GEAR ASSEMBLY

Pinion gear replacement requires complete starter motor disassembly. It is recommended that a complete inspection of all components be performed at that time.

Disassemble Starter

For ease of disassembly and assembly, clamp drive end housing in a vise as shown, Fig. 103.

CAUTION: Take care not to damage drive housing or mounting surface.

1. Remove solenoid.
2. Remove starter thru bolts.
3. Remove brush end cap, Fig. 103.



NOTE: To prevent losing brush springs, do not remove brush retainer **1** until starter housing has been removed from drive end cap, Fig. 103.

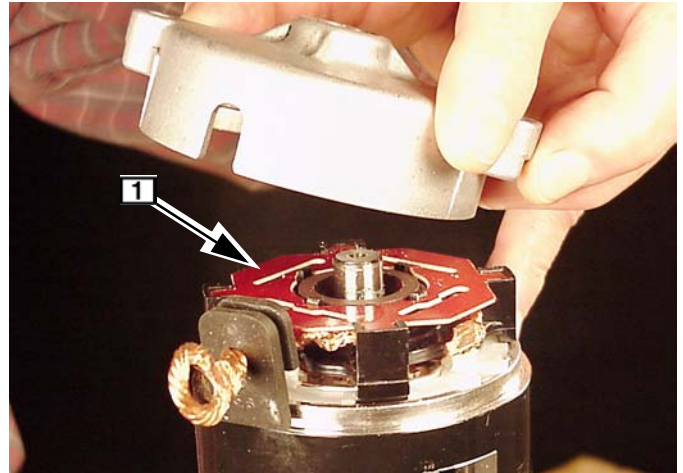

Fig. 103

4. Remove starter housing from drive end cap.



Fig. 104

- Remove armature and pinion gear with drive lever from drive end cap, Fig. 105.



Fig. 105

- Remove spacer from armature shaft.
- Use a 14 mm deep socket and drive retainer from C-ring, Fig. 106.
- Remove and discard C-ring and retainer.

Always use a new C-ring and retainer.



Fig. 106

- Remove pinion gear and clutch assembly, Fig. 107.

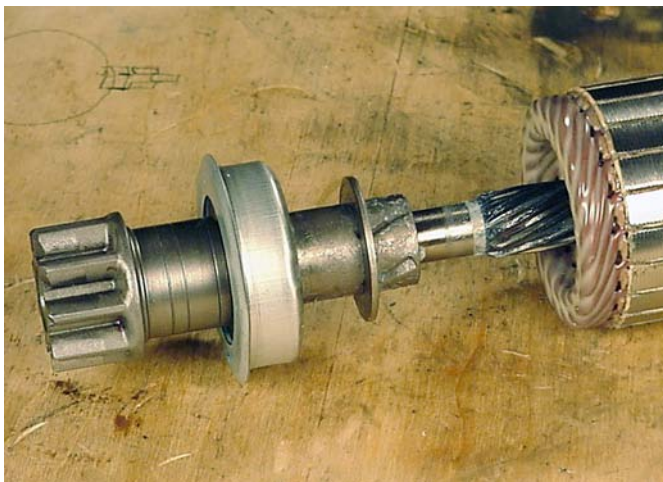

Fig. 107

Clean and inspect helix. If helix is damaged, replace starter. Inspect bearing journals on armature shaft for wear or damage. If bearing journals are worn or damaged, replace starter.



NOTE: Bearings in drive and brush end cap are not replaceable.

Inspect Armature Commutator

The armature commutator may be cleaned with fine sandpaper (#300 - 500 grit). DO NOT use emery cloth. Commutator may be machined to no less than **1.062" (27.0 mm)**, Fig. 108.

Slots between commutator bars should be cleaned with a hack saw blade after cleaning or machining.

The armature should be checked for shorts with a growler.

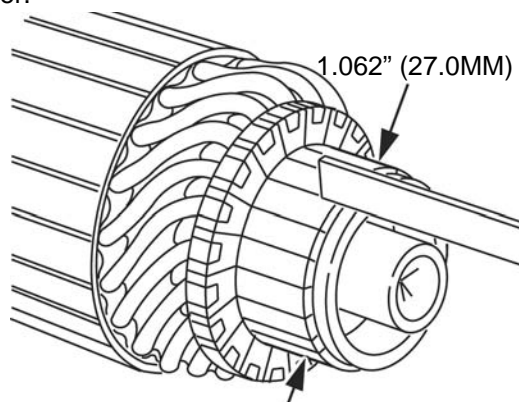

Fig. 108

Inspect Brushes

Minimum brush dimension is 1/4" (6.0 mm). If brushes are worn less than specification, replace the starter housing, Fig. 109.

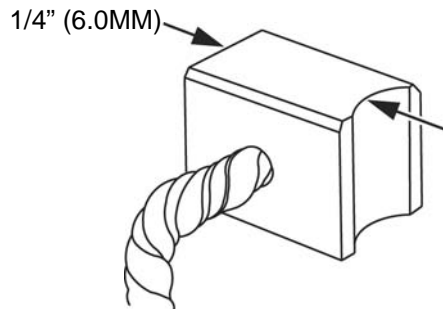

Fig. 109

Use digital multimeter and check for continuity between field coil wire and brushes shown, Fig. 110.

The following test will be made with the meter in the (Diode Test) Position.

1. Attach either meter test lead to field coil wire.
2. Contact first one, then other brush with other test lead as shown.
 - a. Meter should make continuous tone (continuity).
 - b. If meter does not make a tone, (no continuity) replace starter housing.

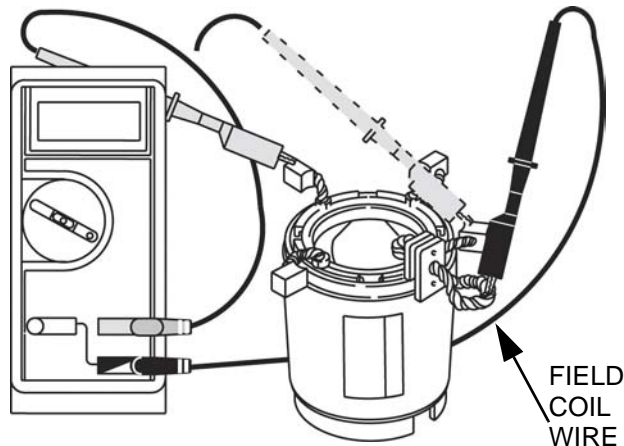

Fig. 110

3. Attach either test lead to starter housing, Fig. 111.
4. Contact first one, then other brush with other test lead as shown.
 - a. Meter should make continuous tone (continuity).
 - b. If meter does not make a tone, (no continuity) replace starter housing.

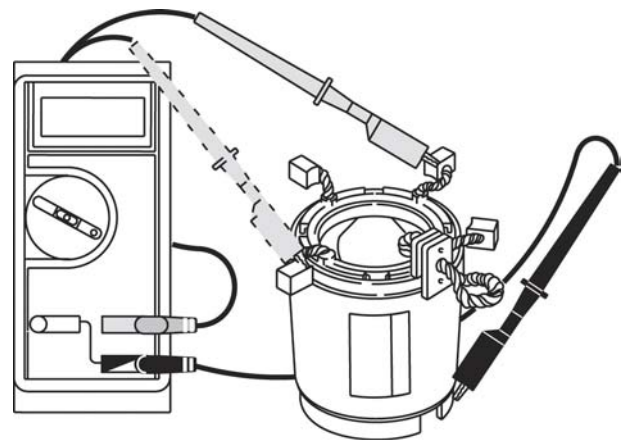

Fig. 111

Assemble Pinion Gear

1. Lubricate helix with a light coat of grease and assemble pinion gear and clutch.
2. Assemble new retainer to shaft.
3. Install new C-ring.
4. Pry up on retainer until C-ring snaps into groove in retainer, Fig. 112.



Fig. 112

5. Assemble spacer to armature shaft, Fig. 113.



NOTE: Lip **1** on spacer must face bearing in drive end cap.



Fig. 113

Assemble Starter

1. Assemble drive lever to pinion and install armature and drive lever into drive housing, Fig. 114.

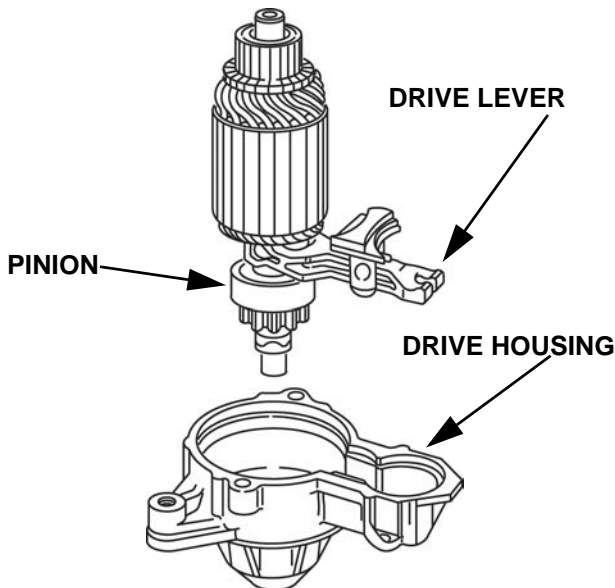

Fig. 114

2. Align tab on drive lever with notch in housing, Fig. 48.

3. Assemble starter housing to drive housing, aligning notch 115.

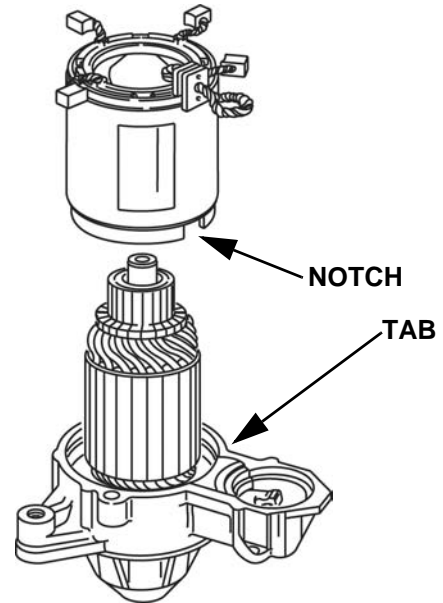

Fig. 115

4. Install brush holder, inserting tabs on brush holder into slots in starter housing, Fig. 116.

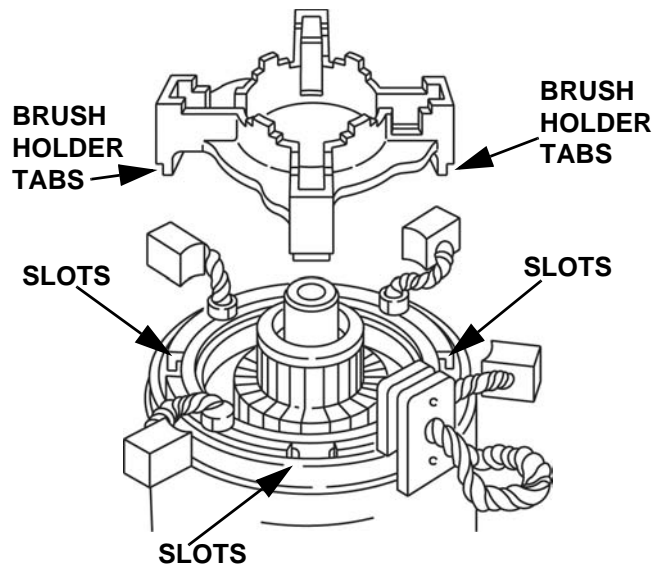

Fig. 116

5. Insert brushes into brush holder, Fig. 117.

6. Compress springs with needle nose pliers and insert spring behind brushes.

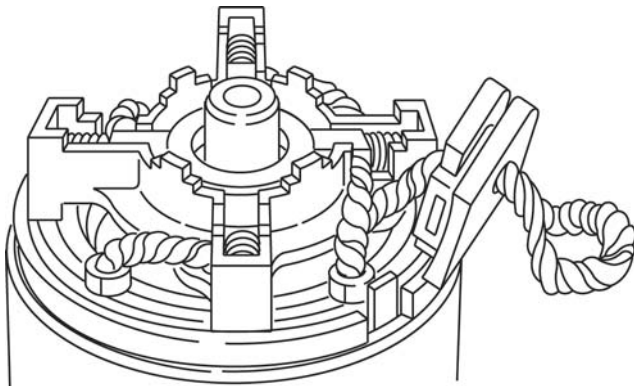

Fig. 117

7. Install brush retainer plate.
8. Assemble rubber seal to starter housing, Fig. 118.
 - a. Be sure notch in rubber seal is inserted over tab on housing.

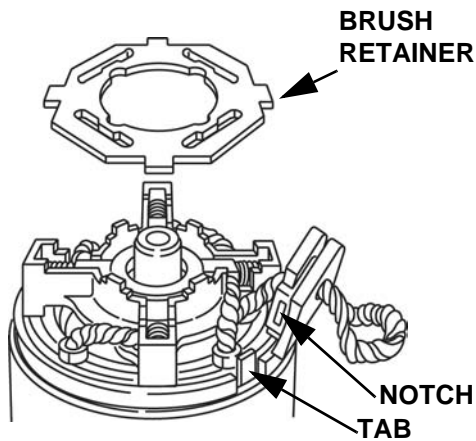

Fig. 118

9. Install end cap, Fig. 119.
 - a. Torque through bolts to 70 in. lbs. (8.0 Nm).

10. Install solenoid.

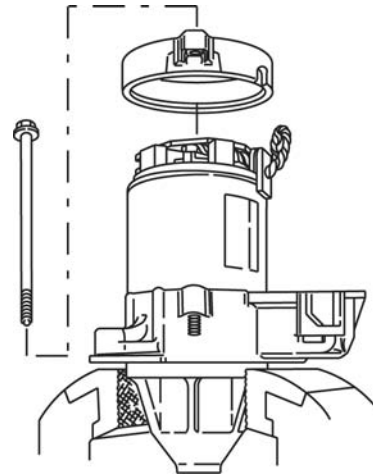

Fig. 119

CARBURETOR INSPECTION AND REPAIR

Disassemble Carburetor

1. Remove fuel shut off solenoid with washer.
2. Remove carburetor lower body screws and lift lower body straight away from upper body, Fig. 120.
 - a. Discard gasket.



Fig. 120

3. Remove fixed main jets [1].



NOTE: Carburetor is equipped with a different size fixed main jet for each cylinder, Fig. 121. The carburetor is marked "L" (#1 cylinder) and "R" (#2 cylinder).

4. Remove pilot jets [2].

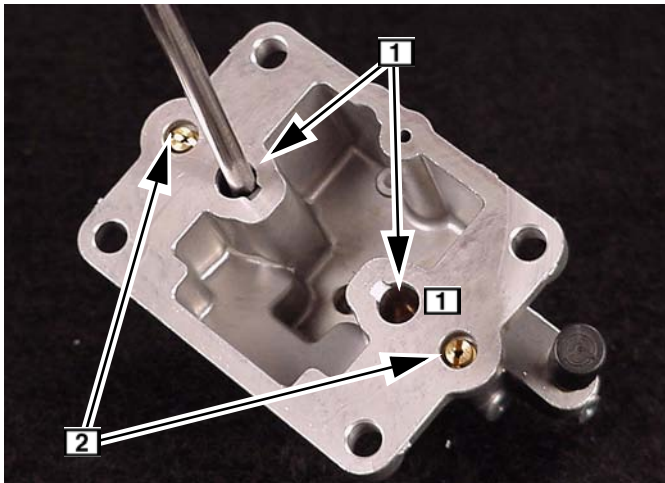

Fig. 121

5. Remove float and inlet valve, Fig. 122.



Fig. 122

If idle mixture screws are equipped with adjustment limiter caps, use a pliers to remove them before removing idle mixture screws.

6. Remove idle mixture screws and springs, Fig. 123.

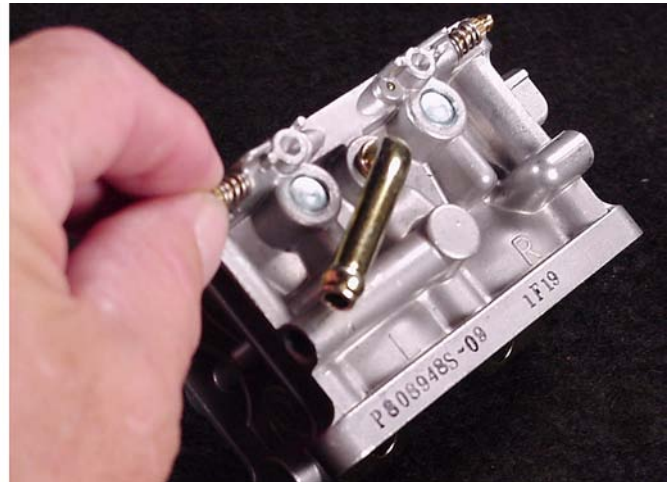

Fig. 123

7. Remove welch plugs, Fig. 124.



Fig. 124

8. Mark throttle plates before removing so that they may be re-installed in the same position. Top and bottom edges are beveled.



9. Remove throttle shaft, spacer and seal, Fig. 125.



Fig. 125

10. Mark choke plate so it may be returned to its original position.
11. Remove choke shaft and nylon bushings, Fig. 126.

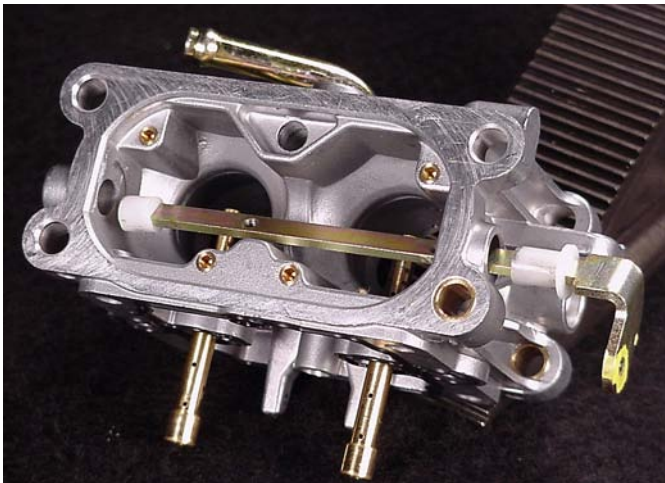

Fig. 126

This completes the carburetor disassembly procedure.

Carburetor Cleaning Recommendations



CAUTION: Wear suitable skin protection when using cleaners and follow instructions on container.

1. Disassemble carburetor.
2. Remove and discard all old gaskets, seals and sealing material.
3. Use commercial carburetor cleaning solvents (such as Briggs & Stratton Spray Cleaner, Part

#100041 or 100042) to clean carburetor parts and body.

4. When cleaning non-metallic parts (plastic, nylon, MinlonE, etc.), do not leave in commercial carburetor cleaner more than 15 minutes.

CAUTION: Parts containing rubber, such as seals, O-rings, inlet needles, seats or pump diaphragms should never be placed in commercial carburetor cleaner. Do not use wires, drills or any other devices to clean out metering holes or passages.



CAUTION: To prevent eye injury, always wear eye protection when using compressed air.

5. Use only compressed air (blowing in both directions) to clean out all openings and passages.

Check Throttle, Choke Shaft And Body For Wear

1. Lay carburetor on a flat surface and check throttle and choke shaft clearance as shown, Fig. 127.

Throttle shaft and choke shaft clearance must not exceed .010" (.25 mm).

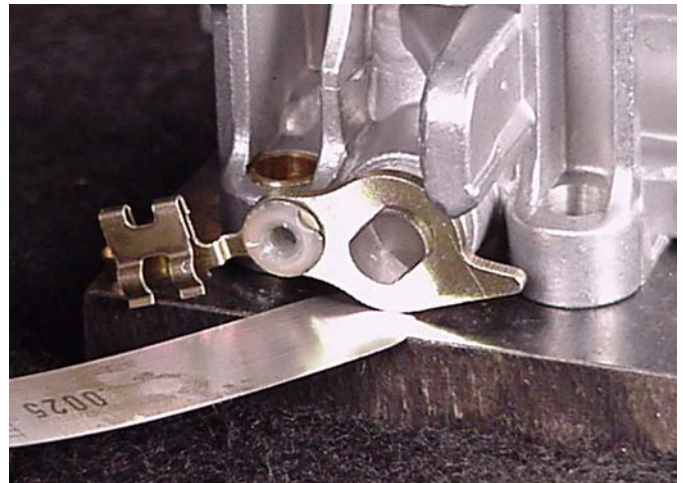

Fig. 127

2. Inspect throttle shaft and choke shaft for wear, Fig. 128. Make sure bushing hole is circular and there is no wear. Replace if worn.

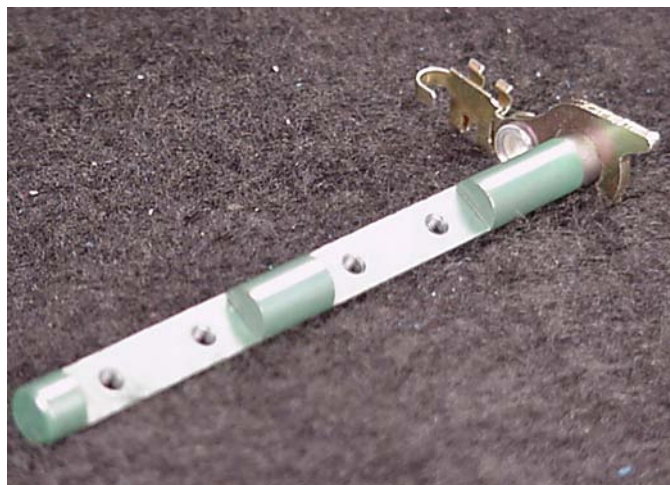

Fig. 128

Assemble Carburetor

When assembling carburetor, use new seals and gaskets.

1. Install new welch plugs with a 5/16" (8 mm) punch, Fig. 129.
2. Use a sealant such as Permatex® #2 or nail polish on outside diameter of plug to prevent air leaks.



Fig. 129

3. Install new throttle shaft seal **1**, Fig. 130.
4. Install throttle shaft with spacer **2**.

IMPORTANT: Install one throttle plate at a time. Check throttle shaft for freedom of operation before installing other throttle plate.



NOTE: Use LOCTITE® 222® on screw threads and torque to 6 in. lbs. (0.7 Nm).

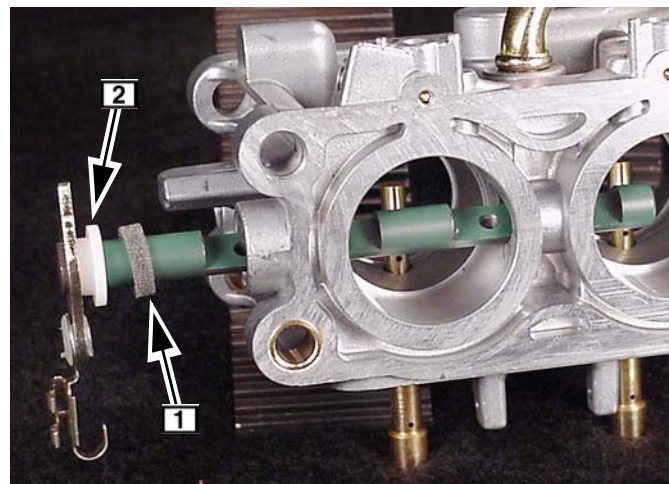

Fig. 130

5. Install choke shaft with new bushings, Fig. 131.
 - a. Lever **1** must face up.
 - b. Install choke plate. Check for binding.



NOTE: Use LOCTITE® 222® on screw threads and torque to 6 in. lbs. (0.7 Nm).

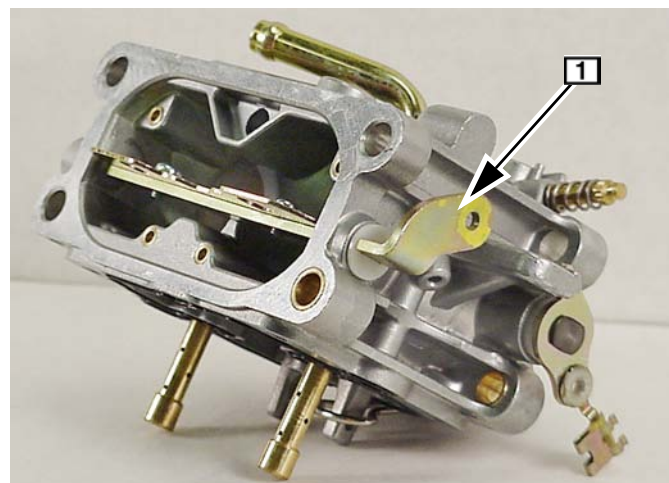

Fig. 131

6. Install idle mixture screws and springs. DO NOT tighten screws at this time, Fig. 132.

DO NOT install limiter caps at this time.



Fig. 132

7. Install main jets and pilot jets, Fig. 133.

“L” or #1 cylinder is equipped with #114 main jet **1**. “R” or #2 cylinder is equipped with #118 main jet **2**. Both pilot jets are #48.

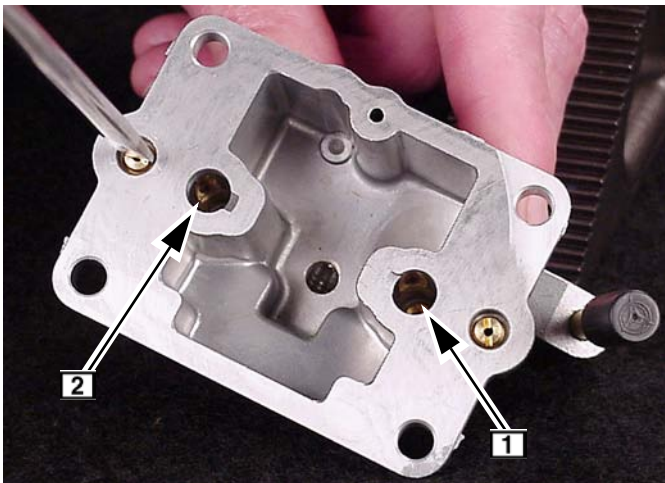

Fig. 133

8. Assemble inlet valve to float and install float assembly, Fig. 134.



Fig. 134

9. Install lower body gasket.

Make sure gasket does not twist or kink.

10. Assemble lower body. Make sure gasket remains in position, Fig. 135. Tighten screws to 22 in. lbs. (2.5 Nm).



Fig. 135

11. Install fuel shut off solenoid with washer.

a. Torque to 90 in. lbs. (10.0 Nm).



NOTES

A large grid of dotted lines for taking notes, consisting of approximately 25 columns and 35 rows.



SECTION 5 ENGINE ASSEMBLY

INSTALL CRANKSHAFT

1. Lubricate mag. bearing and lips of oil seal with engine oil and install crankshaft.
2. Lubricate and install new governor shaft oil seal in cylinder. Then lubricate and install governor shaft **1**, Fig. 136.

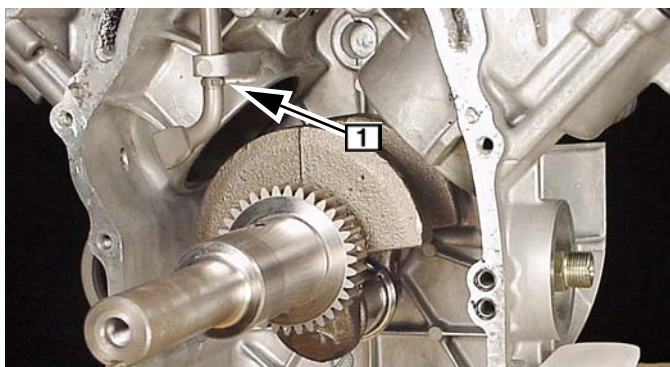

Fig. 136

ASSEMBLE PISTON AND CONNECTING ROD

Lubricate parts with engine oil and assemble #1 piston and connecting rod, Fig. 137.

1. Offset casting mark on piston must face flywheel side.
2. "OUT 1" on connecting rod must face PTO side (opposite notch or casting mark on piston).
 - a. Install piston pin locks with needle nose pliers.

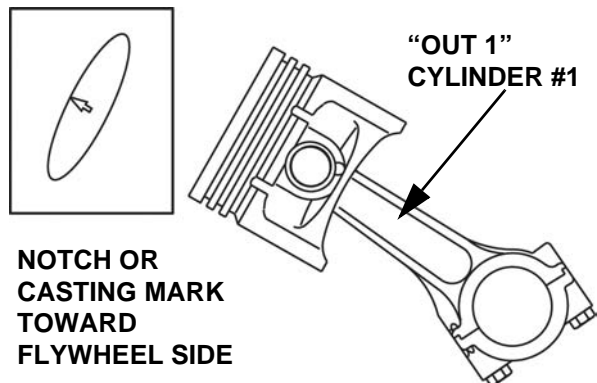

Fig. 137

Lubricate parts with engine oil and assemble #2 piston and connecting rod, Fig. 138.

1. Offset casting mark on piston must face flywheel side.
2. "OUT 2" on connecting rod must face PTO side (opposite notch or casting mark on piston).
 - a. Install piston pin locks with needle nose pliers.

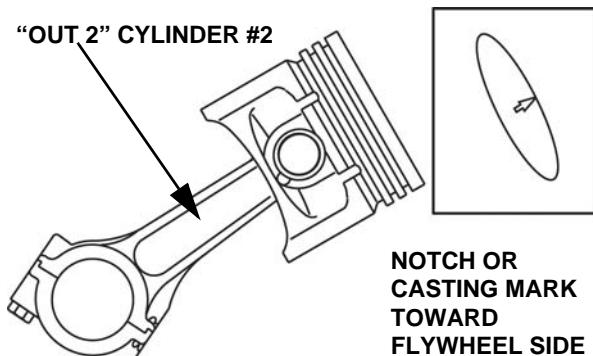

Fig. 138

ASSEMBLE PISTON RINGS TO PISTON

Install rings in order shown, Fig. 139. Use ring expander, Tool #19340 when installing center and top compression rings.

1. Install oil ring expander.
 - a. Install lower scraper ring.
 - b. Install upper scraper ring
2. Install center compression ring with I.D. mark up.



NOTE: Center compression ring is identified by black phosphate coating.

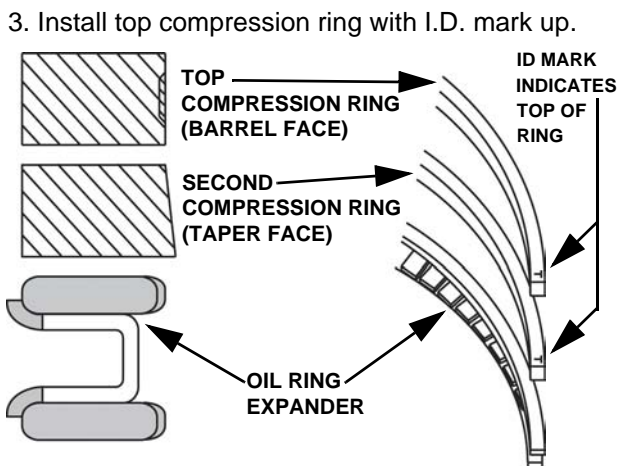

Fig. 139

INSTALL PISTON AND CONNECTING ROD



NOTE: Install #1 piston and connecting rod first.

1. Oil piston rings, piston skirt, and compress rings with ring compressor Tool #19070.
 - a. Place piston and ring compressor upside down on bench with projections on compressor facing up, Fig. 140.
 - b. Tighten ring compressor evenly until rings are fully compressed.
 - c. Then loosen ring compressor very slightly so that compressor can be rotated on piston skirt while holding connecting rod.

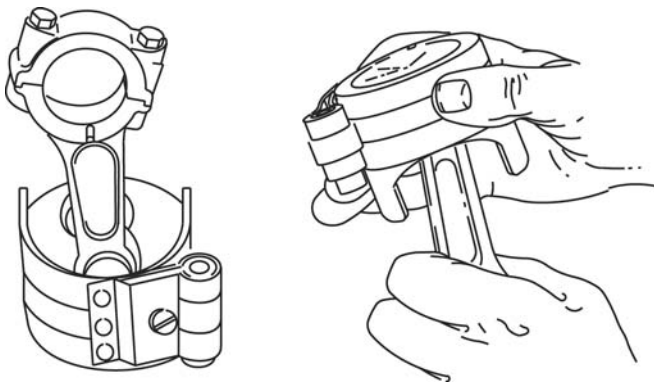

Fig. 140

2. Lubricate cylinder bores and crankpin and rotate crankshaft until it is at bottom of stroke
3. Install #1 piston with notch or offset casting mark on piston toward flywheel side, Fig. 141.

- a. Push piston down by hand until connecting rod is seated on crankpin.

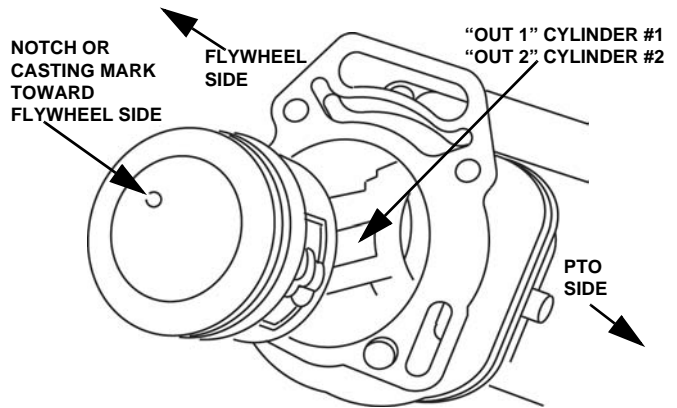

Fig. 141

4. Assemble connecting rod cap to rod with match marks aligned **1**, Fig. 142.
 - a. Torque screws to 125 in. lbs. (14.0 Nm).
5. Rotate crankshaft two revolutions to check for binding. Rod should also be free to move sideways on crankpin.

Repeat for #2 cylinder.

CAUTION: The words "OUT-1" on #1 connecting rod and "OUT-2" on #2 connecting rod must be facing PTO side. Failure to use a torque wrench can result in loose connecting rod screws causing breakage or tight connecting rod screws causing scoring.

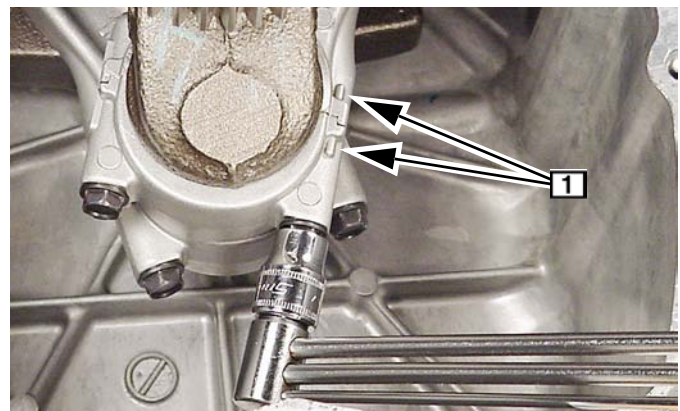

Fig. 142

INSTALL CAMSHAFT

Lubricate tappets, camshaft journals and lobes with engine oil. Assemble timing gear to crankshaft.

1. Install tappets.
2. Align timing marks on camshaft and crankshaft timing gear and install camshaft, Fig. 143.
3. Install new O-rings in cylinder.



Fig. 143

INSTALL GOVERNOR GEAR

1. Lubricate thrust washer **1** and assemble to governor gear shaft, Fig. 144.
2. Install governor gear **2**.

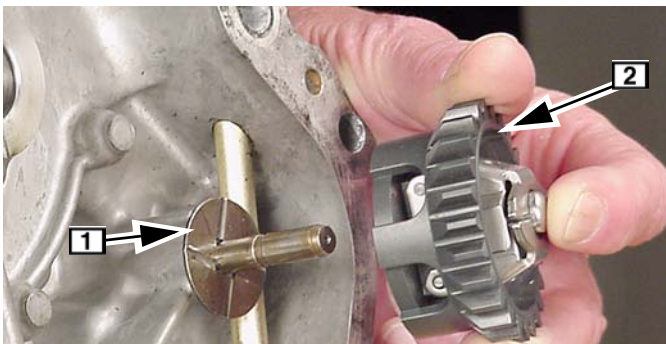

Fig. 144

INSTALL CRANKCASE COVER

1. Install crankcase cover with new gasket making sure that governor gear teeth mesh with teeth on camshaft.
2. Torque screws in sequence shown to 200 in. lbs. (23 Nm), Fig. 145.

3. Check crankshaft end play.

End Play: .004" - .011" (0.09 - 0.26 mm)

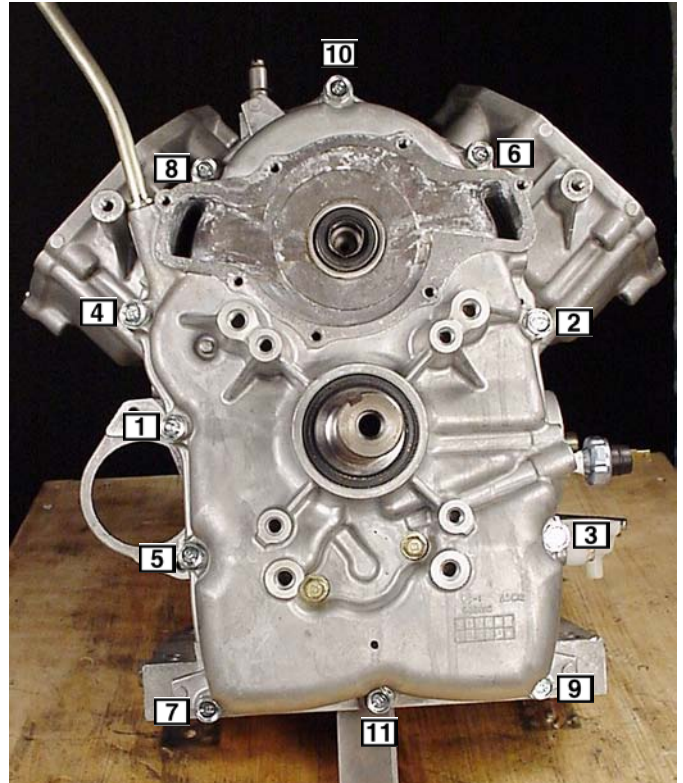

Fig. 145

4. Install water pump impeller, Fig. 146. Torque screw **1** to 90 in. lbs. (10.0 Nm).

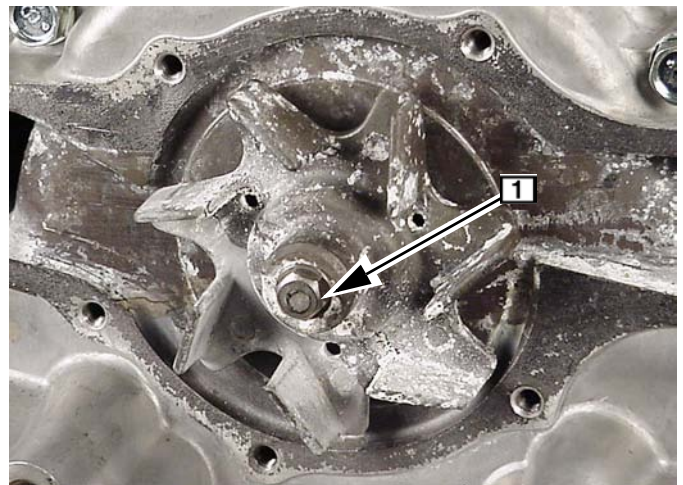

Fig. 146

5. Install water pump cover with new gasket. Torque in sequence shown to **90 in. lbs. (10.0 Nm)**, Fig. 147.

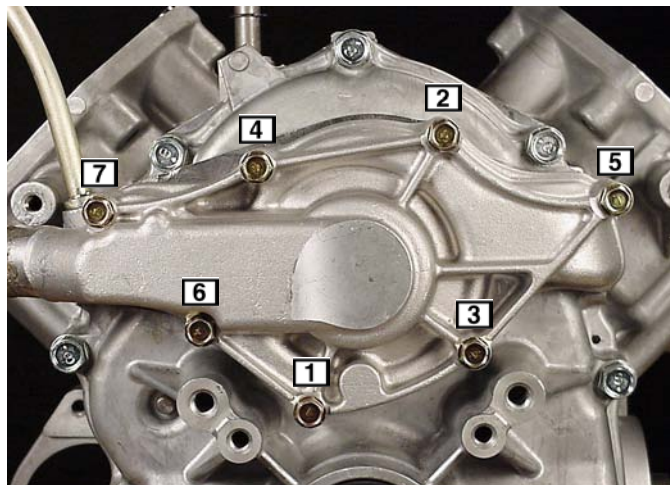

Fig. 147

6. Install breather with new gasket, Fig. 148. Torque screws to **35 in. lbs. (4.0 Nm)**.

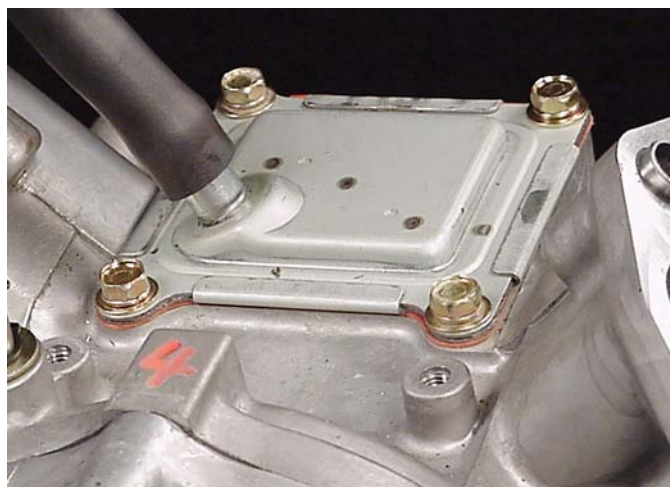

Fig. 148

INSTALL STARTER

Install starter and solenoid assembly, Fig. 149. Torque screws to **140 in. lbs. (16.0 Nm)**.

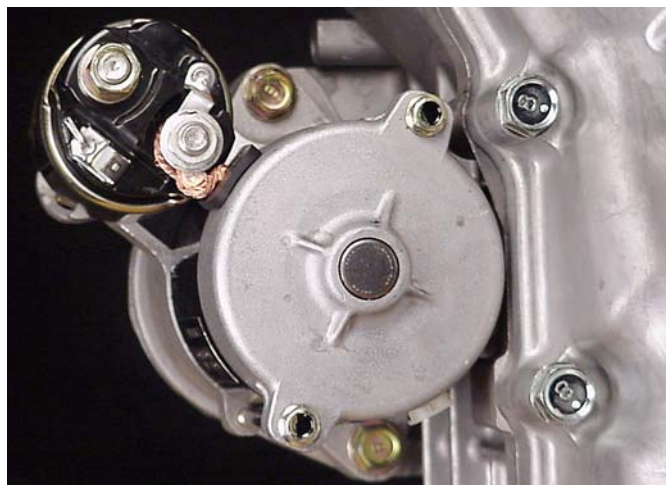

Fig. 149

INSTALL ALTERNATOR

1. Install alternator. Route wires behind mounting boss **1** as shown, Fig. 150. Torque screws to **30 in. lbs. (3.0 Nm)**.
2. Route alternator wires through clamp as shown. Torque clamp **2** to **35 in. lbs. (4.0 Nm)**.

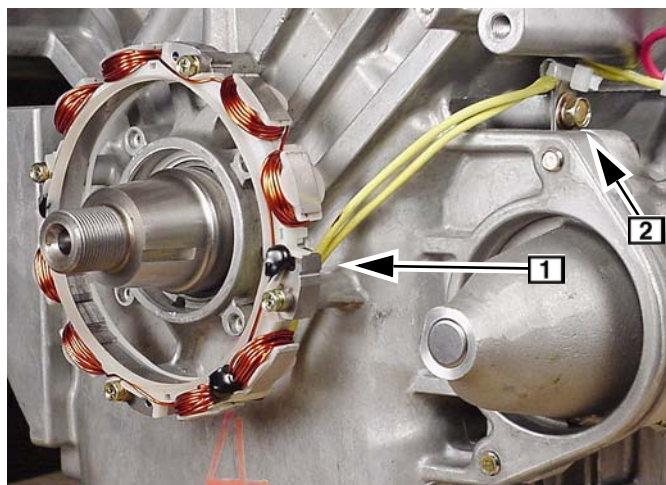

Fig. 150

INSTALL FLYWHEEL

1. Clean flywheel and crankshaft taper. Remove all oil, dirt or grease.
2. Assemble flywheel to crankshaft and align keyways.
3. Insert flywheel key into keyways.
4. Place flywheel strap wrench, Tool #19433 around outer rim of flywheel, Fig. 151. Torque flywheel nut to **150 ft. lbs. (203 Nm)**.
5. Install fan pulley. Torque to **140 in. lbs. (16.0 Nm)**.



Fig. 151

INSTALL CYLINDER HEADS

1. Install cylinder heads with new gaskets.



NOTE: Arrow on gasket must face flywheel side.

2. Lubricate threads of head bolts with Valve Guide Lubricant #93963.



NOTE: Install short head bolt **6** below spark plug hole.

3. Torque bolts in sequence shown to **30 ft. lbs. (40.0 Nm)**, Fig. 152.

4. Insert push rods into recess in tappets.

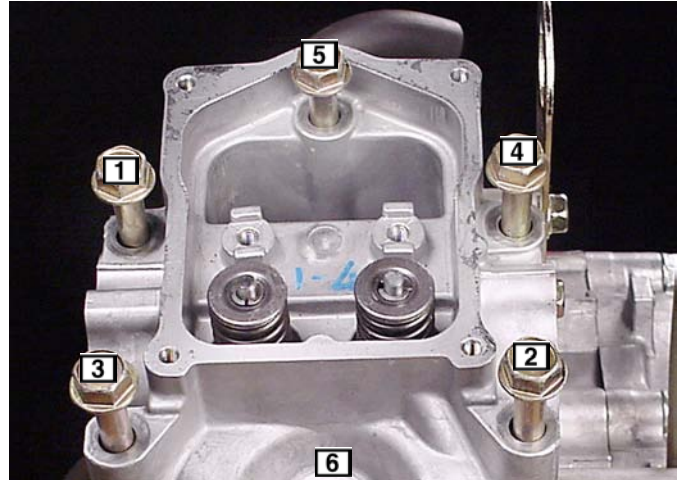

Fig. 152

INSTALL ROCKER ARMS

1. Lubricate rocker arm supports with clean engine oil.
2. Assemble rocker arm supports and rocker arms to cylinder head, Fig. 153. Torque screws to **100 in. lbs. (11.0 Nm)**.

CAUTION: Make sure push rods are seated in recess in rocker arms and tappets.

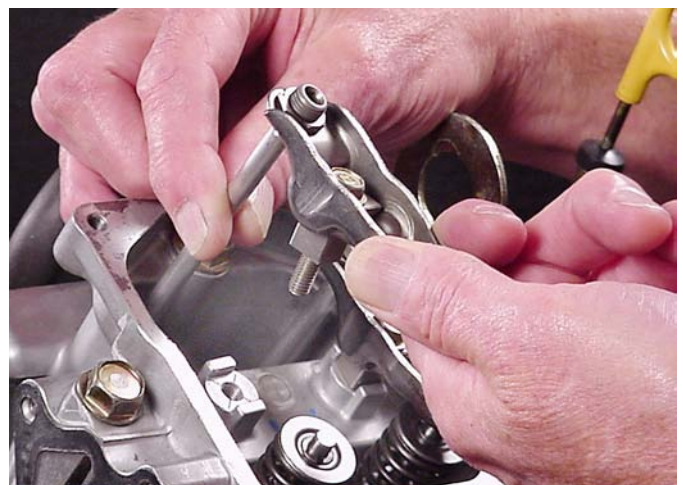

Fig. 153

ADJUST VALVE CLEARANCE

1. Set No. 1 cylinder at 1/4" (6 mm) past TDC, compression stroke.
 - a. Adjust valves and check.

**Valve Clearance (Cold)
IN and EX .008" (0.2 mm)**

- b. Torque lock nut and adjusting screw to **70 in. lbs. (8.0 Nm)**, Fig. 154.
2. Repeat for No. 2 cylinder.
3. Install valve covers with new gaskets. Torque screws to **70 in. lbs. (8.0 Nm)**.



Fig. 154

INSTALL ARMATURES

1. Install ground wire onto tab terminal on armatures.
2. Assemble armature to engine, Fig. 155. Mounting holes in armature are slotted. Push armature away from flywheel as far as possible and tighten one screw to hold armature in place.
3. Repeat for second armature.



NOTE: Make sure wires are routed over armature mounting posts.

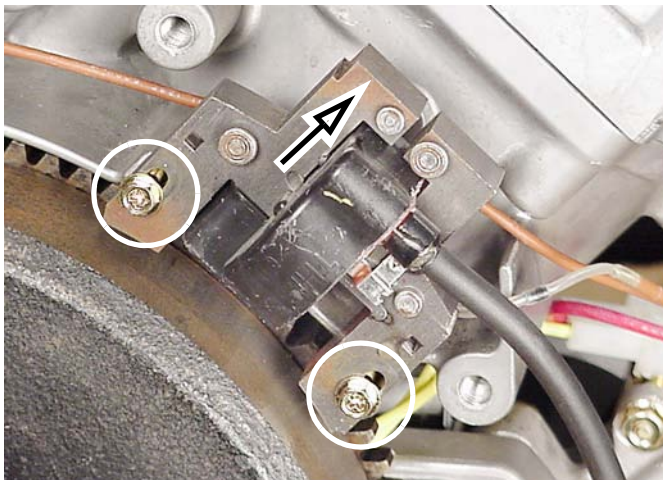

Fig. 155

1. Rotate flywheel until magnet is under armature laminations.
2. Place thickness gauge **1** .005" - .007" (0.13 - 0.18 mm) between magnet and armature laminations, Fig. 156.
3. Loosen mounting screw so magnet will pull armature down against thickness gauge. Torque screws to **30 in. lbs. (3.0 Nm)**.
4. Rotate flywheel to remove thickness gauge.
5. Repeat for second armature.

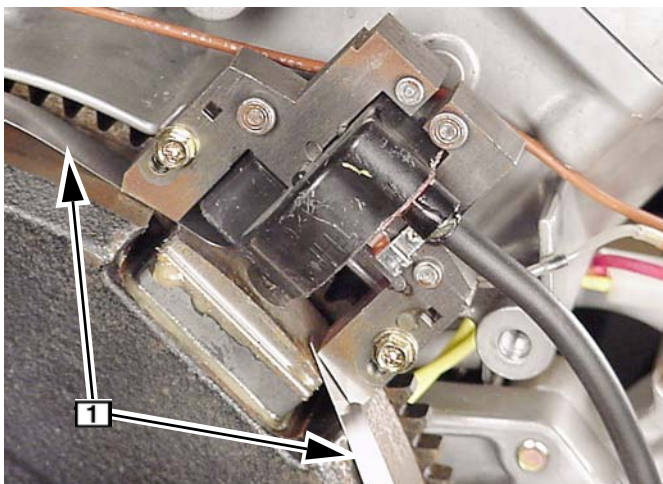

Fig. 156



NOTE: If engine is equipped with an oil pressure switch, route wire over armature mounting bosses and attach to pressure switch at this time.

INSTALL FAN ASSEMBLY

1. Install fan brackets, Fig. 157. Torque screws **1** to 150 in. lbs. (17.0 Nm).



NOTE: Take care not to pinch wires between fan brackets and cylinder.

2. Assemble fan belt to upper fan pulley.

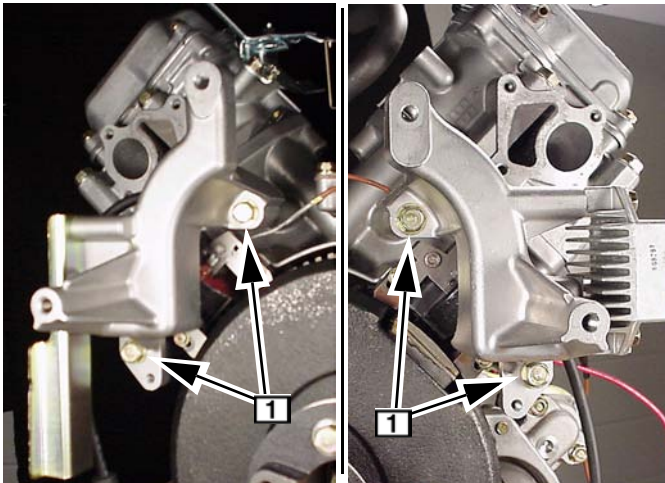

Fig. 157

3. Place fan belt over lower pulley and assemble fan and adjustment bracket to fan brackets. Install upper pivot screw. Then install adjustment screw.
4. Fit torque wrench **1** in the square hole in adjustment bracket.
5. Apply and hold 115 in. lbs. (13.0 Nm) torque to bracket, Fig. 158.
 - a. Torque adjustment screw **2** to 110 in. lbs. (12.0 Nm).

- b. Torque pivot screw **3** to 125 in. lbs. (14.0 Nm).

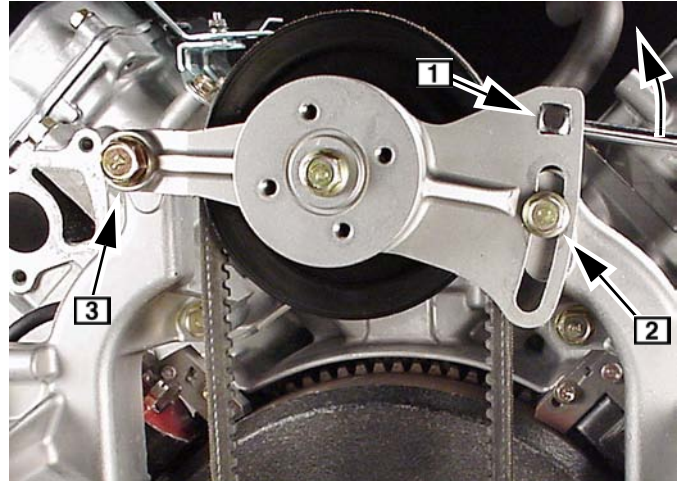

Fig. 158

6. Install fan, Fig. 159. Torque screws to 70 in. lbs. (8.0 Nm).



Fig. 159

7. Install flywheel housing, Fig. 160. Torque screws **1** to 60 in. lbs. (7.0 Nm).

8. Connect regulator-rectifier to alternator.

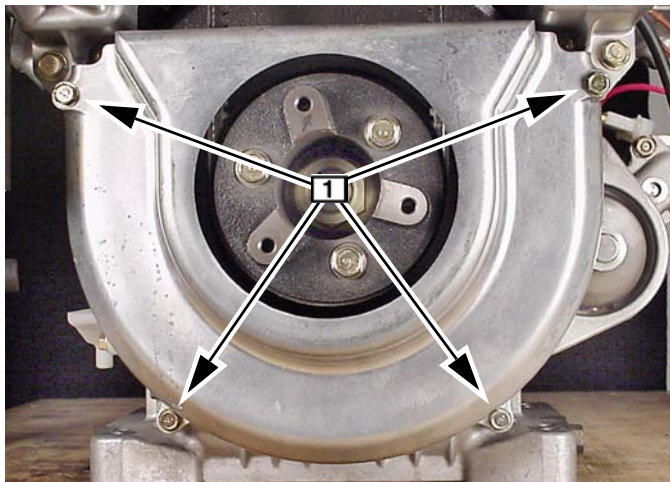

Fig. 160

INSTALL INTAKE MANIFOLD

1. Install intake manifold with new gaskets, Fig. 161.
Torque screws to 90 in. lbs. (10.0 Nm).

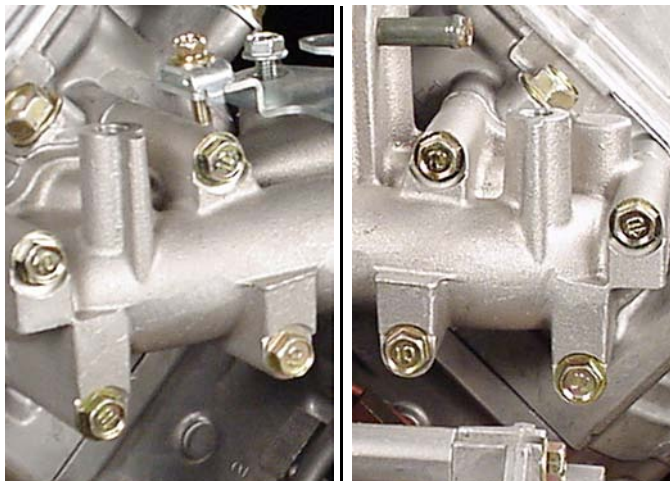

Fig. 161

2. Assemble governor link to governor bracket and install governor control bracket, Fig. 162. Torque screws to 70 in. lbs. (8.0 Nm).

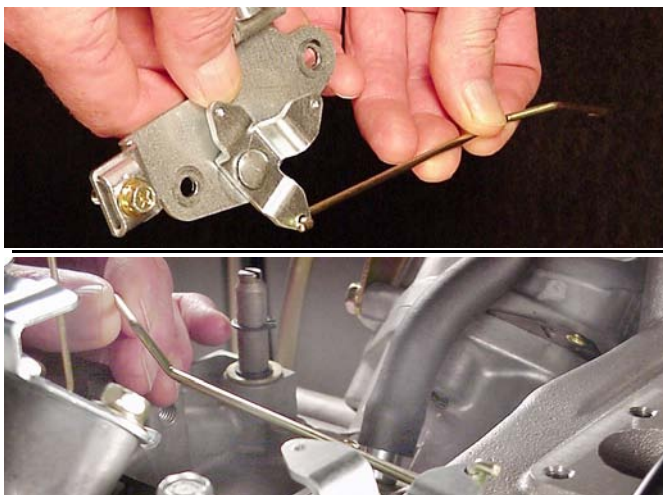

Fig. 162

INSTALL CARBURETOR AND INTAKE ELBOW ASSEMBLY

Assemble choke link to choke control lever, Fig. 163.



Fig. 163

1. Assemble air cleaner elbow and carburetor to intake elbow with new gaskets, Fig. 164. Torque screws to 90 in. lbs. (10.0 Nm).

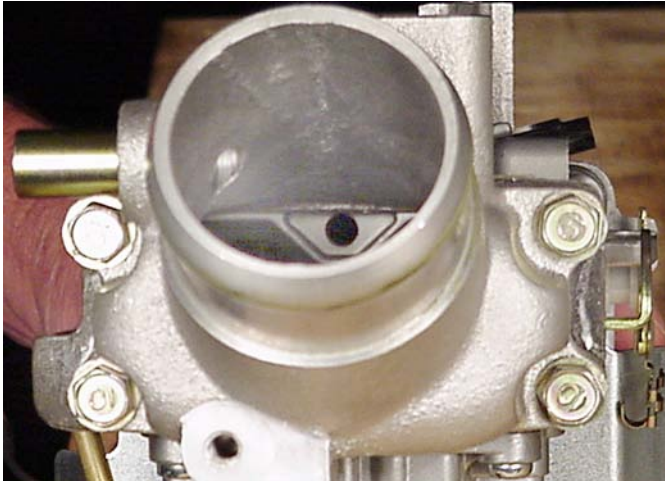

Fig. 164

2. Assemble choke link to choke lever and install carburetor and intake elbow assembly, Fig. 165. Torque screws **1** to 90 in. lbs. (10.0 Nm).
3. Connect breather tube to air cleaner elbow.
4. Connect fuel shut off solenoid wire and install ground wire.

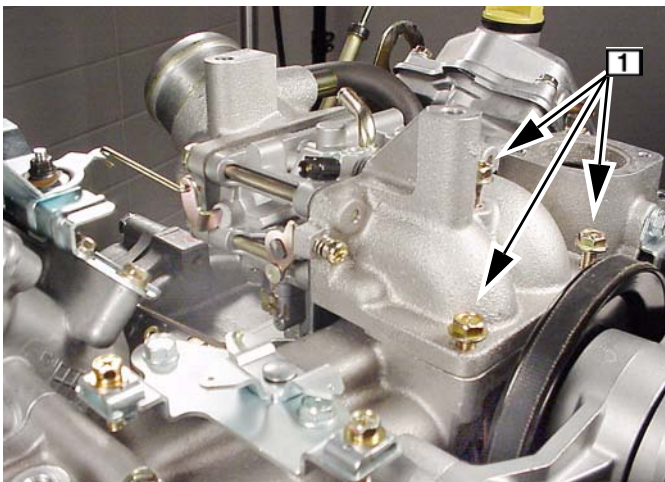

Fig. 165

5. Assemble governor link to governor control bracket and install governor control bracket, Fig. 166. Torque screws to 70 in. lbs. (8.0 Nm).

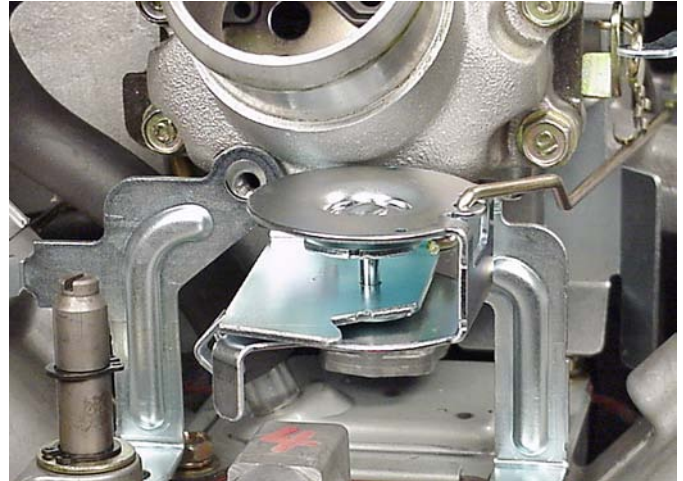

Fig. 166

6. Assemble governor springs to governor control bracket, Fig. 167.

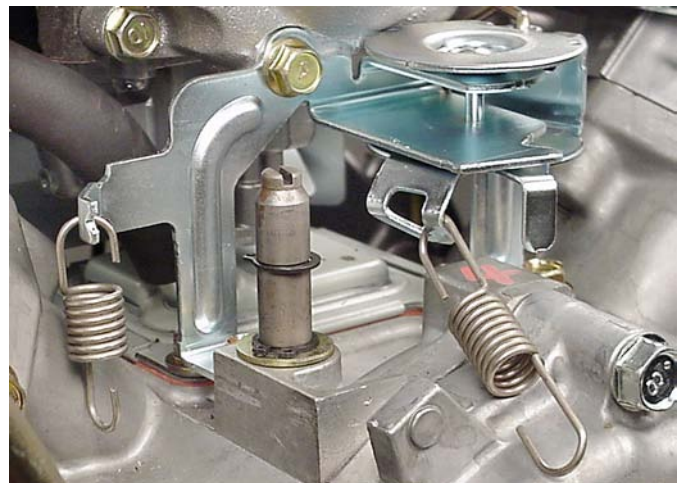

Fig. 167

7. Assemble throttle link and spring to governor lever, Fig. 168.
8. Then, assemble governor springs to governor lever and assemble governor lever to governor shaft.

Do Not tighten governor lever nut at this time.

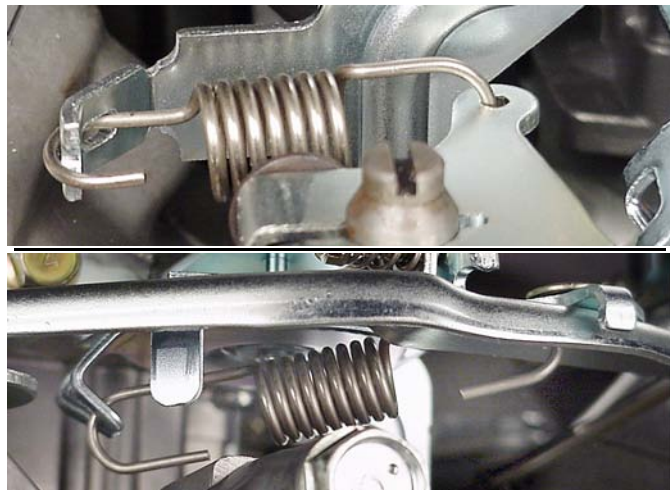

Fig. 168

9. Assemble throttle link and spring to throttle lever on carburetor, Fig. 169.

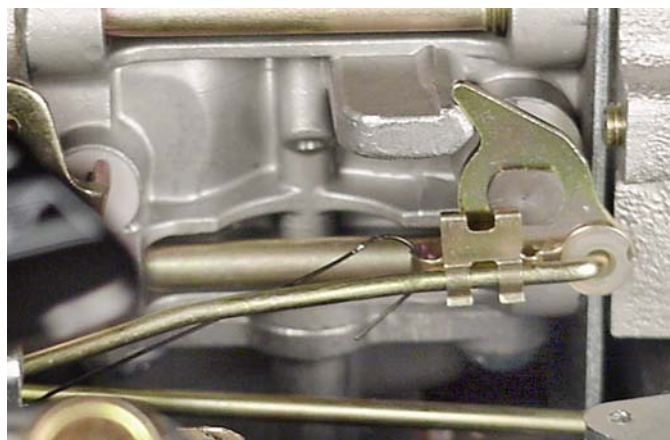

Fig. 169

ADJUST GOVERNOR



CAUTION: BEFORE STARTING OR RUNNING ENGINE, static adjustment of the governor must be completed! Failure to make the static adjustments first could result in engine overspeeding which may result in engine damage, property damage or personal injury.

Static Governor Adjustment

1. With governor lever nut loose, rotate governor control swivel clockwise as far as it will go (wide open throttle) and hold in this position, Fig. 170.
2. Rotate governor shaft counter-clockwise as far as it will go. Torque governor nut to **70 in. lbs. (8.0 Nm)**.

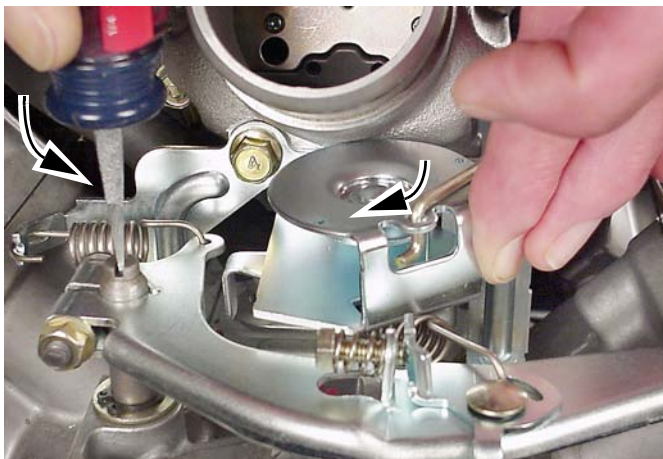

Fig. 170

INSTALL MUFFLER

1. Install muffler with new gaskets, Fig. 171. Torque screws to **190 in. lbs. (21.0 Nm)**.

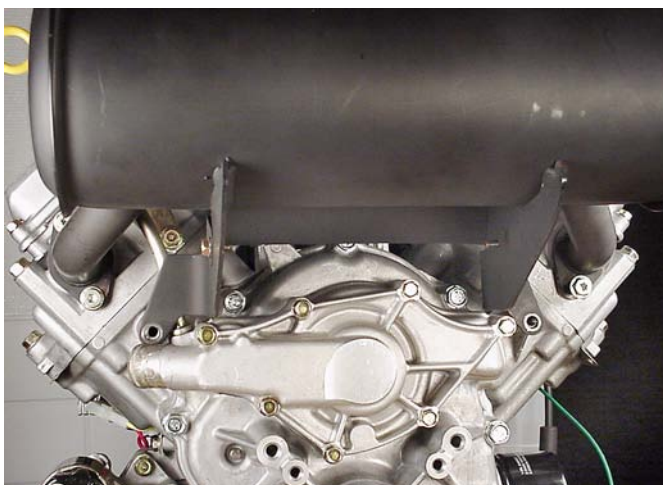

Fig. 171

INSTALL RADIATOR

1. Install fan shroud assembly, Fig. 172. Torque screws to **140 in. lbs. (16.0 Nm)**. Maintain a 1/8" (3 mm) gap between the shroud and the radiator to prevent wear from vibration.

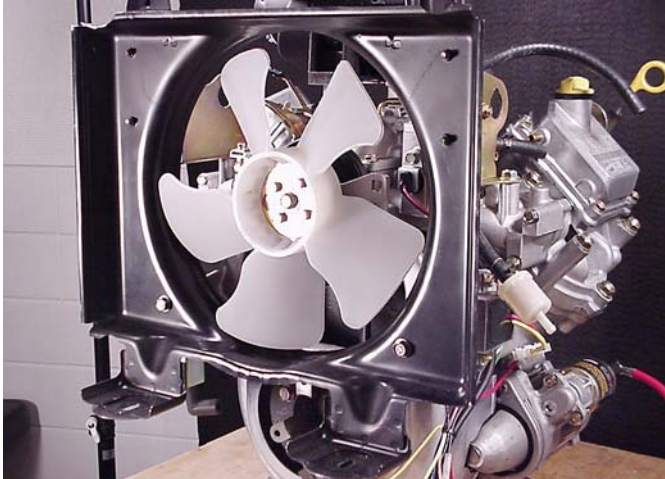

Fig. 172

2. Install radiator, Fig. 173. Torque nuts with washers to **100 in. lbs. (11.0 Nm)**. Torque lower mounting nuts first, then upper mounting nuts.

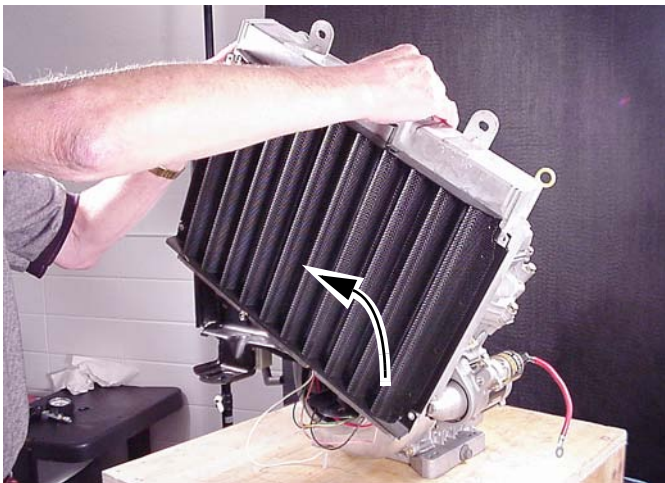

Fig. 173

3. Install fuel line from pump to carburetor **1**, and fuel pump pulse line at valve cover **2**, Fig. 174.

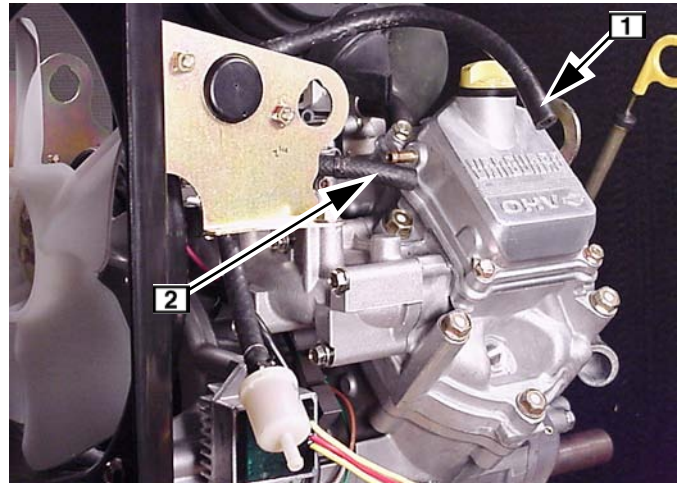

Fig. 174

4. Install thermostat and thermostat housing with new gasket, Fig. 175. Torque screws to **70 in. lbs. (8.0 Nm)**.



Fig. 175

5. Install radiator hoses.

INSTALL AIR CLEANER ASSEMBLY

IMPORTANT: The air cleaner mounting bracket holes are slotted, Fig. 176.

- The front mounting hole **1** is slotted crosswise (radiator side).
- The rear mounting hole **2** is slotted length wise (muffler side).

- The inside band of the mounting bracket has locating tabs **3** that fit into notches in the air cleaner housing.

This allows the air cleaner housing to be rotated in a number of positions in case of clearance concerns in certain equipment applications.

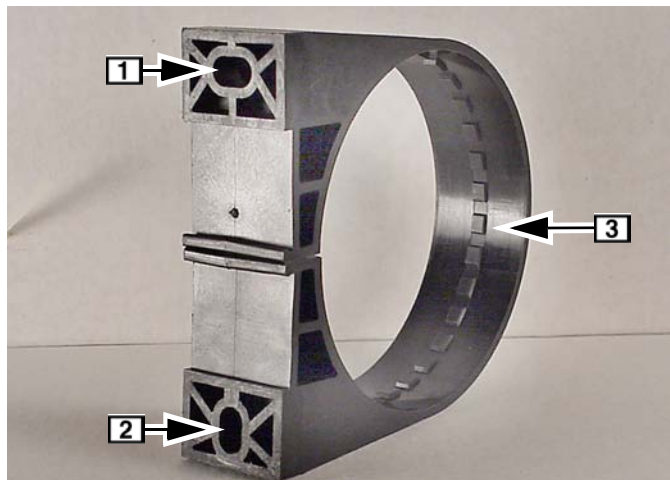

Fig. 176

1. Assemble mounting bracket to air cleaner housing with front mounting hole **1** towards air inlet side **2**, Fig. 177.
2. Rotate air cleaner housing so that base of mounting bracket is parallel to air inlet tube.

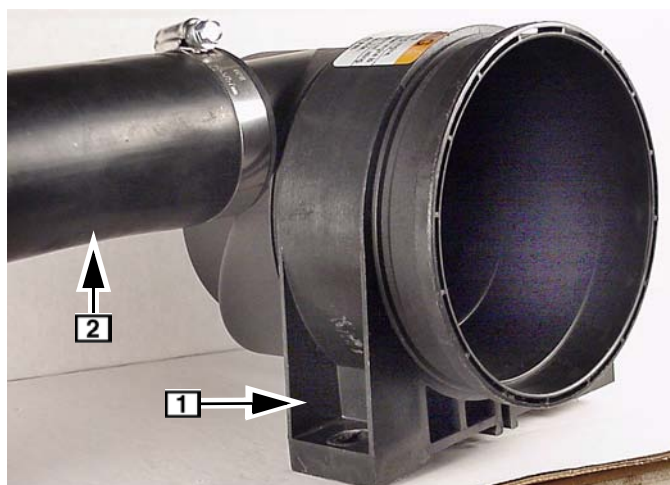

Fig. 177

3. Assemble air cleaner housing and mounting bracket to engine and install front mounting

screw, Fig. 178. Torque front screw to **90 in. lbs. (10 Nm)**.

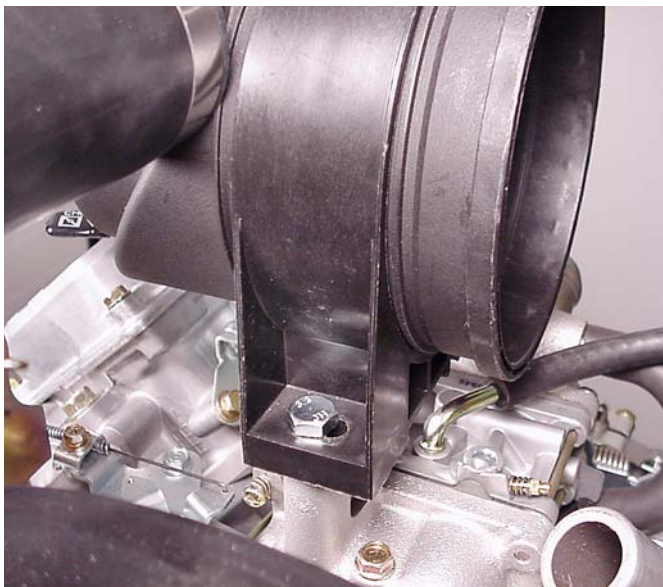

Fig. 178

4. Install rear mounting screw **1** loosely.
5. Push on rear mounting bracket to eliminate any slack in mounting bracket. Hold in this position, Fig. 179. Torque rear screw to **90 in. lbs. (10 Nm)**.

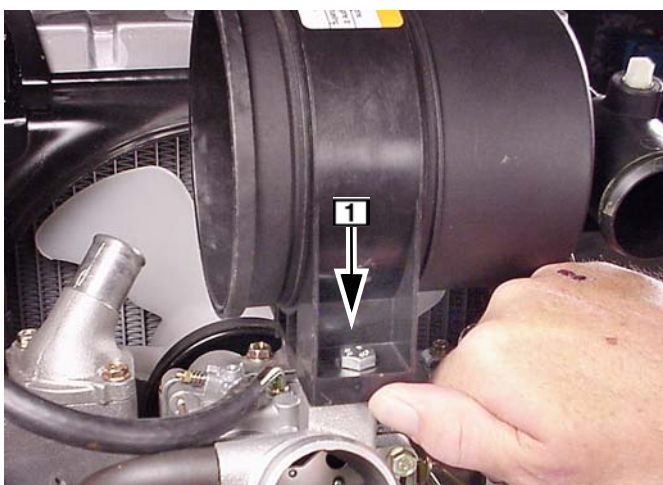

Fig. 179

6. Assemble air cleaner cartridge air outlet tube in air cleaner housing. Push cartridge onto tube as far as it will go.
7. Install intake elbow tube.

8. Install air cleaner cover with arrows facing up, Fig. 180.

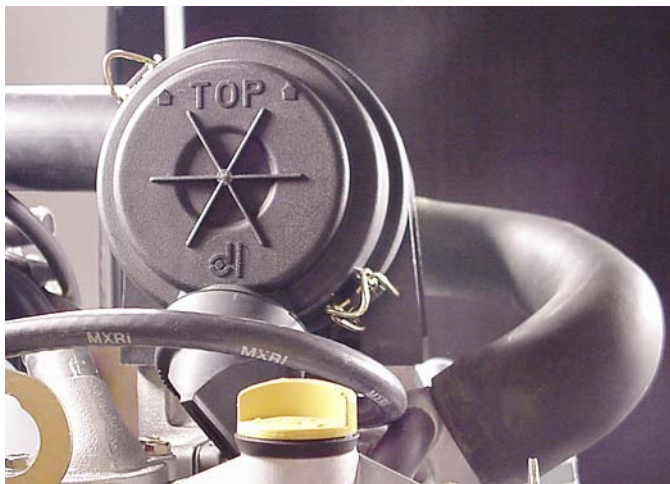

Fig. 180

Refer to Section 6 for final adjustment procedures.



NOTES

A large grid of dotted lines for taking notes, consisting of 20 columns and 30 rows.

SECTION 6 FINAL ADJUSTMENTS AND SPECIFICATIONS

GENERAL INFORMATION

The purpose of the mechanical governor is to maintain, within certain limits, a desired engine speed, even though loads may vary. The governor spring tends to pull the throttle open. The force of the flyweights, which are operated by centrifugal force, tends to close the throttle. The engine speed at which these two forces balance is called the governed speed. The governed speed can be varied by changing governor spring tension. If a governor spring must be replaced, consult the appropriate Illustrated Parts List. Select the proper governor springs by engine type number.



NOTE: After a new governor spring is installed, check engine top governed speed with an accurate tachometer.

REMOTE GOVERNOR CONTROLS

VanguardE liquid cooled OHV Twin cylinder engines are equipped for remote governor controls, Fig. 181.

Speed Regulation

Remote governor controls (supplied by equipment manufacturer) control engine speed by increasing or decreasing tension on governor spring(s) to obtain desired engine speed at all positions.

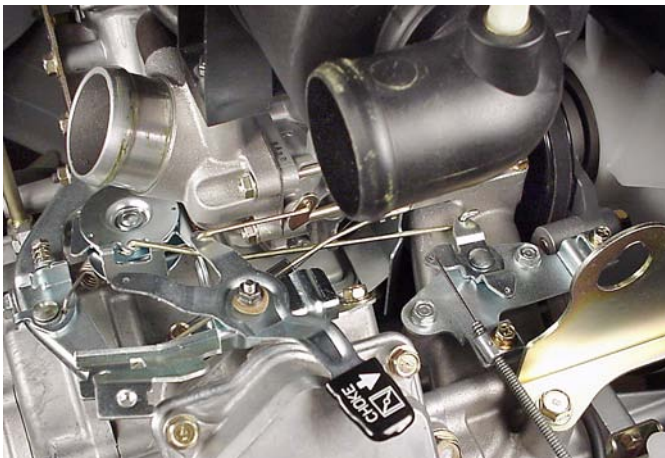

Fig. 181

Governed Idle

VanguardE liquid cooled OHV Twin cylinder engines are equipped with a governed idle system, Fig. 182. A throttle restrictor **1** permits the engine to maintain engine speed when a load is applied with the equipment control in the SLOW position.

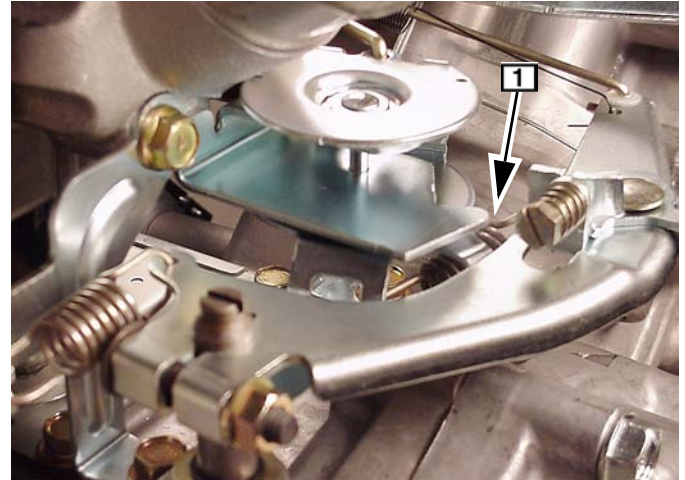

Fig. 182

Remote Control Wire Travel

In order to make proper remote control adjustments, the travel of the remote control wire must be **not less than 1-3/8" (35 mm)** with controls mounted in equipment, Fig. 183.

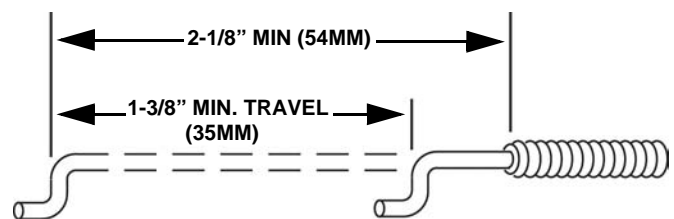

Fig. 183

Speed Control Wire Adjustment

1. Loosen control casing clamp at governor control bracket.
2. Move speed control lever to "FAST" position.
3. Move control casing and wire in direction shown by arrow until governor control swivel is at end of travel, Fig. 184.

4. Tighten casing clamp screw.

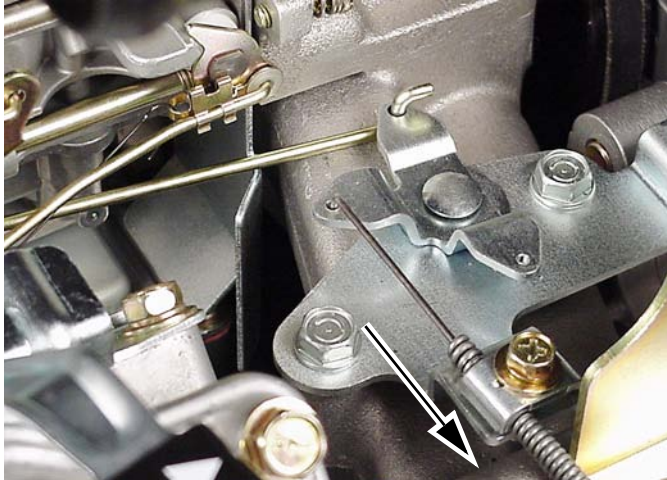

Fig. 184

Choke Control Adjustment

1. Place choke control lever on equipment in **CHOKE** position.
2. Loosen control casing clamp screw.
3. Move control casing and wire until choke is completely closed, Fig. 185.
4. Tighten casing clamp screw.



Fig. 185

CARBURETOR ADJUSTMENT

The VanguardE liquid cooled OHV Twin cylinder carburetor fuel mixture adjustment procedure is unique. Perform adjustments exactly in the sequence shown.

Initial Adjustment

1. Turn idle mixture screw for #1 cylinder clockwise until it just seats. **DO NOT FORCE**.
2. Then turn screw counter-clockwise 3/4 turn, Fig 186.
3. Repeat for #2 cylinder.

This setting will permit engine to start. Final adjustment will be made with engine running.

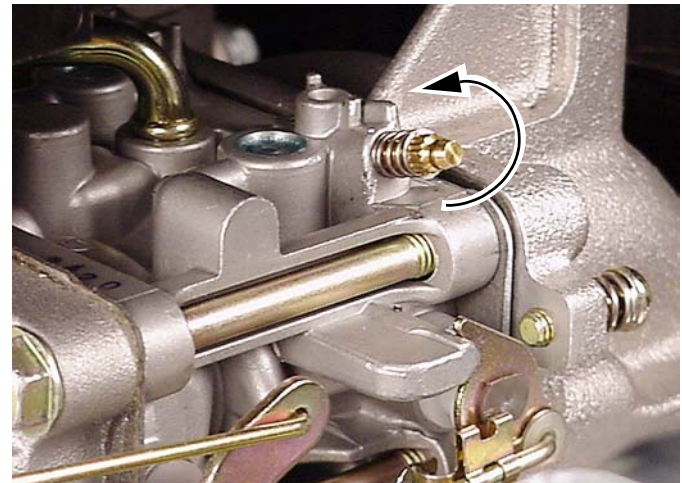

Fig. 186

CAUTION: Failure to follow these instructions may result in bearing seizure

1. When engine has been reassembled after any major repairs, fill engine with a multi-viscosity oil to the recommended level.
2. Then run engine for 5 minutes under **NO** belt tension.
3. Then adjust belt tension to OEM specifications.

Final Adjustment

IMPORTANT: Idle mixture adjustment must be performed with the engine running at 1200 rpm.

The following tools are required when making carburetor adjustments.

1. An accurate tachometer, such as Tool #19389 **1**.
2. Tang bender, Tool #19480 **2**.

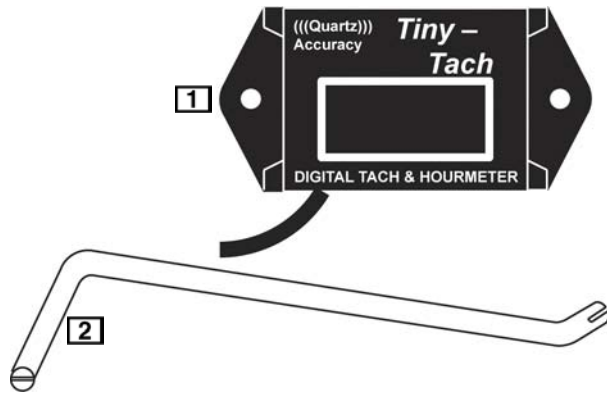

Fig. 187

Start engine and run it for approximately 5 minutes to allow engine to reach operating temperature.

1. Move equipment control lever to "SLOW" position.
2. Hold throttle lever against idle speed screw **1** and temporarily adjust idle to 1200 RPM, Fig. 188.
3. While holding throttle lever, SLOWLY turn idle mixture screw for #1 cylinder clockwise until engine speed just starts to slow (lean mixture).
4. Then, turn idle mixture screw counterclockwise 3/8 turn.



NOTE: It may be necessary to readjust idle speed screw to 1200 RPM before proceeding.

5. Adjust idle mixture screw for #2 cylinder as described in steps 3 and 4.
6. Now, readjust idle speed screw to 1650 RPM.

7. Release throttle lever. Note RPM.

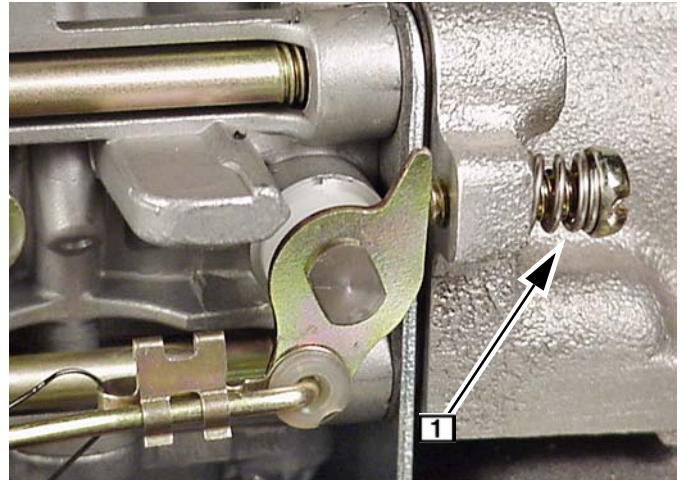

Fig. 188

8. If necessary, use tang bending Tool, #19480, **1** and bend governed idle tang to obtain 1850 RPM, Fig. 189.

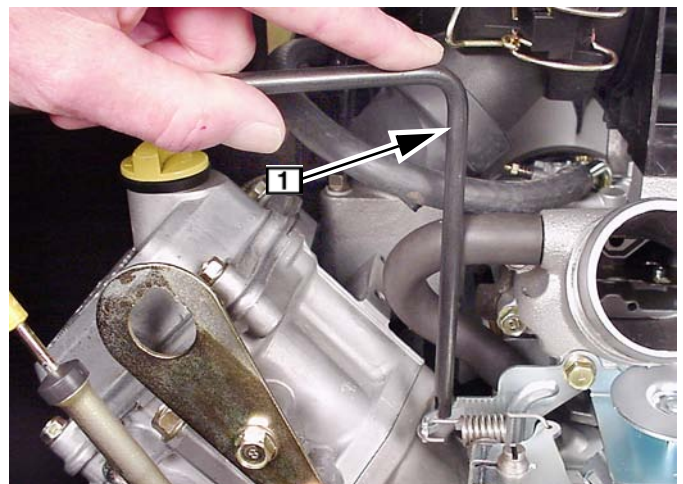

Fig. 189

9. IF CARBURETOR IS EQUIPPED WITH IDLE MIXTURE LIMITER CAPS, INSTALL AT THIS TIME.
 - a. Position limiter cap so that stop on limiter cap is at mid point between stops on carburetor body. Press limiter into position using knock out pin **1**, Tool #19135, Fig. 190.

b. Repeat for other idle mixture valve.

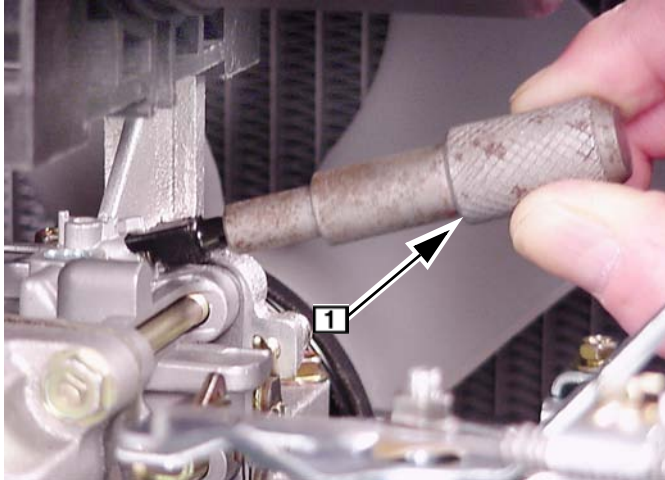

Fig. 190

10. With equipment control lever in “SLOW” position and engine running at governed idle RPM, use tang bender, Tool #19480, and bend throttle restrictor tang **1** so that tang just contacts governor lever, Fig. 191.

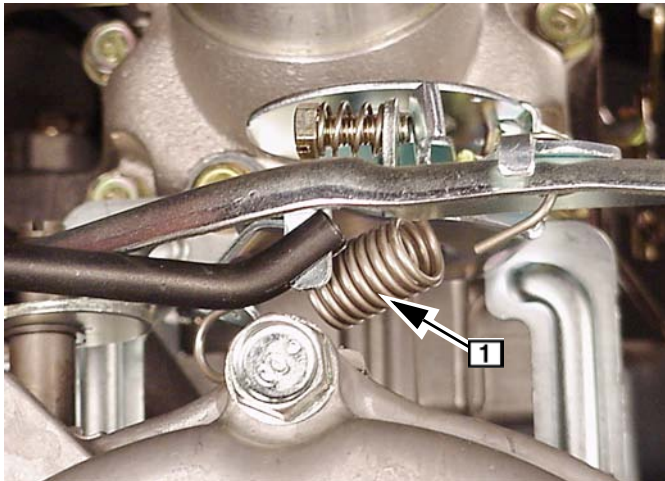

Fig. 191

11. Move equipment control to **FAST** position. Engine should accelerate smoothly. (Readjust idle mixture valve 1/8 turn richer if necessary.)
12. Move control throttle lever to **FAST** position and check engine RPM.

13. Bend tang with Tool #19480 to obtain 3600 RPM, Fig. 192.

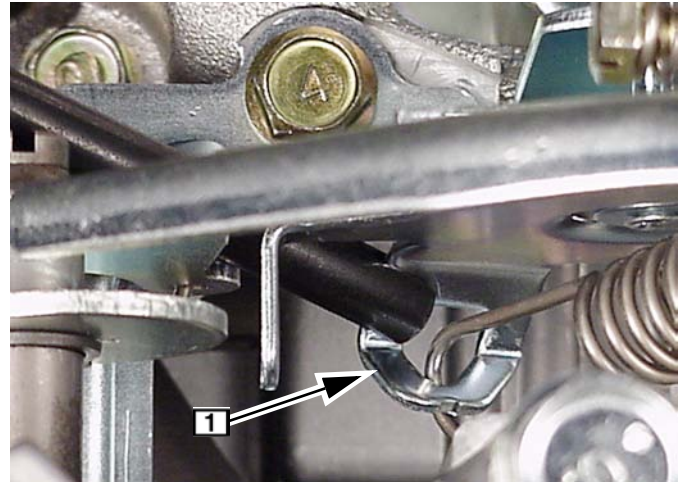

Fig. 192

N **NOTE:** To obtain precise Top No Load speed, turn final adjustment swivel screw clockwise to increase speed or counter-clockwise to decrease speed, Fig. 193.

Final tune adjustment not to exceed + 50 RPM

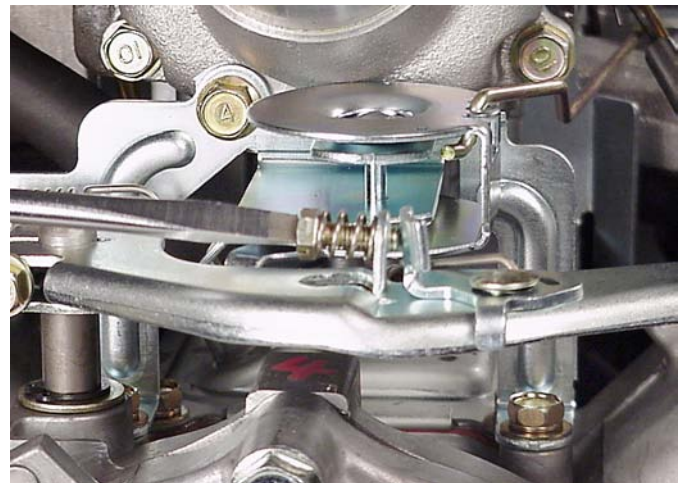

Fig. 193



MODEL 473100 SPECIFICATIONS

Common Specifications

ARMATURE AIR GAP	.005" - .007" (0.13 - 0.18 MM)
BORE	3.190" (81.02 MM)
CRANKSHAFT END PLAY	.004" - .011" (0.09 - 0.26 MM)
COOLANT CAPACITY	3.7 QTS. (3.5 L)
DISPLACEMENT	45.9 CU. IN. (752 CC)
GOVERNED TOP SPEED	3600 RPM
GOVERNED IDLE SPEED	1850 RPM
OIL CAPACITY	87 OZ. (2.6 L)
SPARK PLUG GAP	.020" (.51 MM)
STROKE	2.870" (73.0 MM)
VALVE CLEARANCE (COLD)	
INTAKE	.007" - .010" (0.18 - 0.27 MM)
EXHAUST	.007" - .010" (0.18 - 0.27 MM)

Fastener Specifications

AIR CLEANER SUPPORT BRACKET	90 IN. LBS. (10.0 NM)
AIR CLEANER ELBOW	90 IN. LBS. (10.0 NM)
ARMATURE	30 IN. LBS. (3.5 NM)
BREATHER	35 IN. LBS. (4.0 NM)
CARBURETOR (TO MANIFOLD)	90 IN. LBS. (10.0 NM)
CHOKE CONTROL BRACKET	60 IN. LBS. (7.0 NM)
CONNECTING ROD	125 IN. LBS. (14.0 NM)
CRANKCASE COVER	200 IN. LBS. (23.0 NM)
CYLINDER HEAD	30 FT. LBS. (40.0 NM)
EXHAUST MANIFOLD	190 IN. LBS. (22.0 NM)
FAN BELT ADJUSTMENT SCREW	110 IN. LBS. (12 NM)
FAN BELT PIVOT SCREW	125 IN. LBS. (14.0 NM)
FAN BRACKET (TO CYLINDER)	150 IN. LBS. (17.0 NM)
FAN RETAINER SCREWS	70 IN. LBS. (8.0 NM)
FAN SHROUD (TO FAN BRACKET - 8 MM)	40 IN. LBS. (16.0 NM)
FAN SHROUD BRACKET (TO CYLINDER)	140 IN. LBS. (16.0 NM)
FAN SHROUD BRACKET (TO SHROUD - 6 MM)	70 IN. LBS. (8.0 NM)
FUEL PUMP	60 IN. LBS. (7.0 NM)
FLYWHEEL	150 FT. LBS. (203.0 NM)
FLYWHEEL HOUSING	60 IN. LBS. (7.0 NM)
GOVERNOR CONTROL BRACKET	70 IN. LBS. (8.0 NM)
GOVERNOR LEVER NUT	70 IN. LBS. (8.0 NM)
INTAKE ELBOW (TO MANIFOLD)	90 IN. LBS. (10.0 NM)
INTAKE MANIFOLD	140 IN. LBS. (16.0 NM)
MUFFLER BRACKET	190 IN. LBS. (22.0 NM)
OIL PUMP	70 IN. LBS. (8.0 NM)
ROCKER ARM LOCK NUT	60 IN. LBS. (7.0 NM)
ROCKER ARM STUD	100 IN. LBS. (11.0 NM)
SPARK PLUG	180 IN. LBS. (20.0 NM)
STARTER MOTOR	140 IN. LBS. (16.0 NM)
STARTER MOTOR THROUGH BOLTS	50 IN. LBS. (6.0 NM)
VALVE COVER	70 IN. LBS. (8.0 NM)
WATER PUMP COVER	90 IN. LBS. (10.0 NM)
WATER PUMP IMPELLER BOLT	90 IN. LBS. (10.0 NM)



Standard And Reject Dimensions

DESCRIPTION	STANDARD DIMENSION	REJECT DIMENSION
CYLINDER		
CYLINDER BORE	3.190" (81.02 MM)	3.193" (81.10 MM)
OUT OF ROUND0015" (0.04 MM)
MAIN BEARING (MAGNETO)	1.775" (45.09 MM)	1.7765" (45.12 MM)
CAM BEARING (MAGNETO)788" (20.01 MM)790" (20.06 MM)
CYLINDER HEAD		
VALVE GUIDE237" (6.02 MM)240" (6.09 MM)
VALVE STEM234" (5.95 MM)233" (5.92 MM)
CRANKCASE COVER		
MAIN BEARING (PTO)	1.775" (45.09 MM)	1.7765" (45.12 MM)
CAM BEARING (PTO)788" (20.01 MM)790" (20.06 MM)
CRANKSHAFT		
CRANKPIN	1.654" (42.01 MM)	1.6525" (41.97 MM)
MAGNETO JOURNAL	1.771" (44.99 MM)	1.7695" (44.94 MM)
PTO JOURNAL	1.771" (44.99 MM)	1.7695" (44.94 MM)
CAMSHAFT		
JOURNALS786" (19.95 MM)7845" (19.92 MM)
LOBES	1.346" (34.18 MM)	1.341" (34.06 MM)
CONNECTING ROD		
CRANKPIN BEARING	1.656" (42.07 MM)	1.658" (42.11 MM)
PISTON PIN BEARING8275" (21.02 MM)8285" (21.04 MM)
PISTON PIN		
.8268" (21.0 MM)826" (20.98 MM)
PISTON PIN BEARING (PISTON)		
.827" (21.01 MM)828" (21.03 MM)
PISTON RING		
RING END GAP		
TOP011" (0.28 MM)030" (0.76 MM)
CENTER018" (0.45 MM)030" (0.76 MM)
OIL018" (0.45 MM)030" (0.76 MM)
RING SIDE CLEARANCE		
TOP - CTR.002" (0.05 MM)005" (0.13 MM)
OIL004" (0.010 MM)007" (0.18 MM)



ENGINE HARNESS

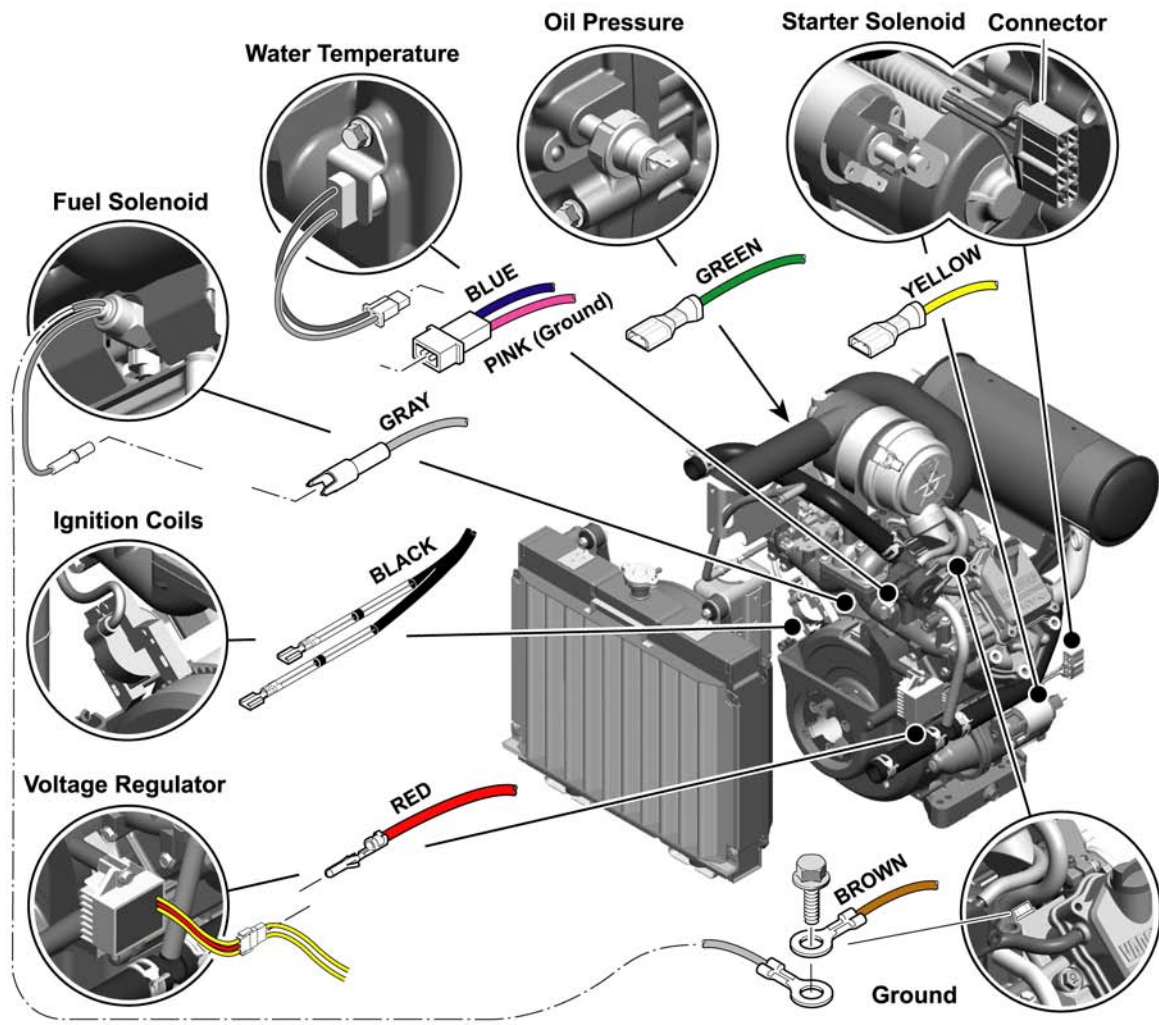
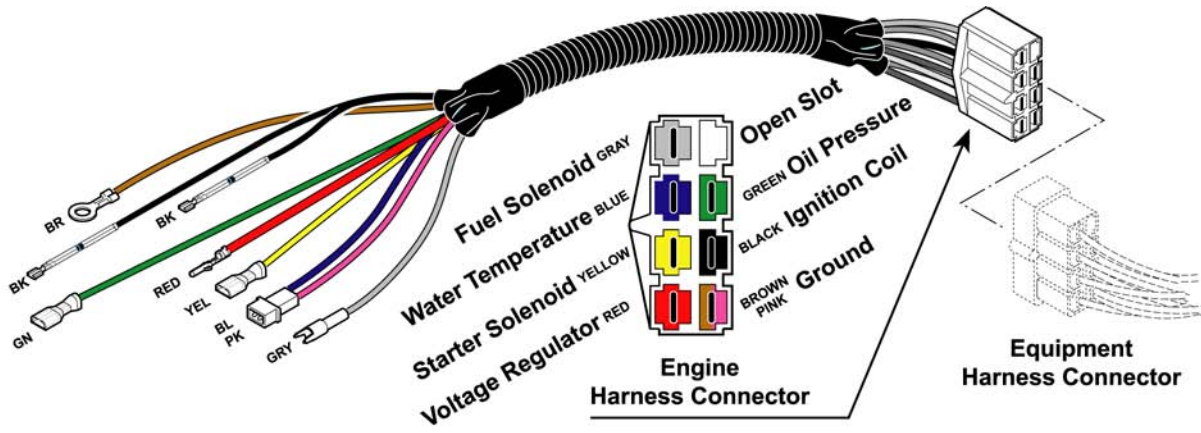



NOTES

A large grid of dotted lines for taking notes, consisting of approximately 20 columns and 30 rows.



NOTES

A large grid of dotted lines for taking notes, consisting of approximately 20 columns and 30 rows.



NOTES

A large grid of dotted lines for taking notes, consisting of approximately 25 columns and 35 rows.